

143H

Motor Grader



Global Version

Cat 3176C DITA ATAAC

Variable Horsepower Arrangement, Net

- gears 1-3	123 kW	165 hp
- gears 4-8	138 kW	185 hp

Variable Horsepower Plus Arrangement, Net

- gears 1-3	123 kW	165 hp
- gears 4-6	128 kW	185 hp
- gears 7-8	153 kW	205 hp

Weights

Gross Vehicle Weight - base	15 270 kg	33,670 lb
front wheels	4305 kg	9493 lb
rear wheels	10 965 kg	24,177 lb

Moldboard

Blade Width	3658 mm	12 ft
-------------	---------	-------

Engine

Engine Model	Cat 3176C DITA ATAAC, Variable HP	
VHP - gears 1-3 Net	123 kW	165 hp
- gears 4-8 Net	138 kW	185 hp
VHP Plus - gears 1-3 Net	123 kW	165 hp
- gears 4-6 Net	138 kW	185 hp
- gears 7-8 Net	153 kW	205 hp
VHP - gears 1-3 Gross	136 kW	182 hp
- gears 4-8 Gross	151 kW	202 hp
VHP Plus - gears 1-3 Gross	136 kW	182 hp
- gears 4-6 Gross	151 kW	202 hp
- gears 7-8 Gross	166 kW	222 hp
VHP AWD on - gears 1-3 Gross	151 kW	202 hp
- gears 4-8 Gross	166 kW	222 hp
VHP Plus AWD on - gears 1-3 Gross	151 kW	202 hp
gears 4-6 Gross	166 kW	222 hp
gears 7-8 Gross	180 kW	242 hp
Displacement	10.3 L	629 in ³
Bore	125 mm	4.9 in
Stroke	140 mm	5.5 in

Torque rise	50%	
Max torque @ 1000 RPM	1095 N·m	808 lb ft
Speed @ rated power	2000 RPM	
Number of cylinders	6	
Derating altitude	3048 m	10,000 ft
Std - Fan speed - max	1350 RPM	
- min	500 RPM	
Std - Ambient Capability	47° C	117° F

- Net power is tested per ISO 9249, SAE J1349, and EEC 80/1269 standards in effect at the time of manufacture.
- VHP Plus is an optional arrangement.
- Net power advertised is the power available at rated speed of 2000 RPM, measured at the flywheel when engine is equipped with fan, air cleaner, muffler, and alternator.
- No derating required up to 3048 m (10,000 ft) altitude. Deration rate of 1.5% per 304.8 m (1000 feet) above 3048 m (10,000 feet).

VHP VHP Plus



Gears 4 - 8 Gears 4 - 6

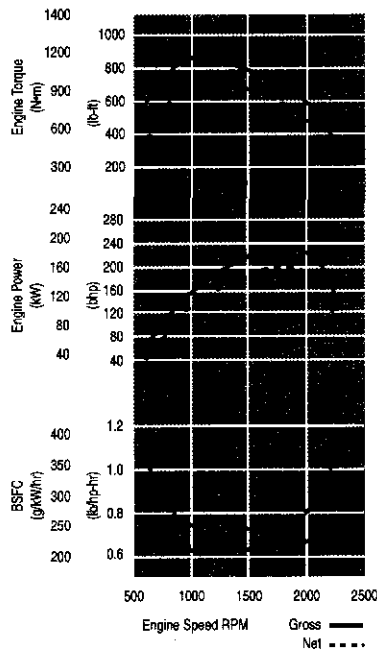

Gears 7 - 8

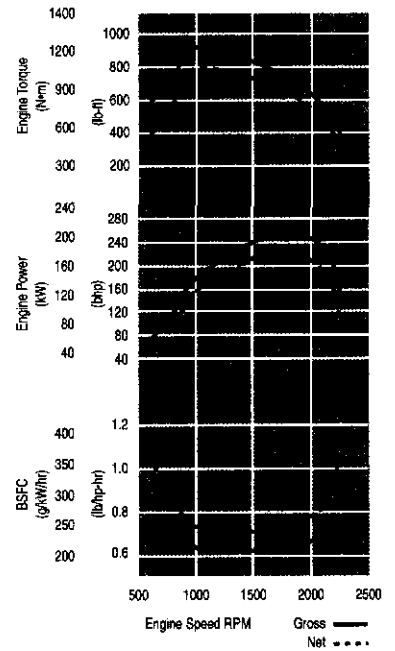

Power Train

Forward/Reverse Gears	8 fwd/6 rev	
Transmission	Direct drive, power shift	
Brakes, Service	air-actuated, oil-disc	
Brakes, Service - surface area	23 948 cm ²	3,712 in ²
Brakes, Parking	manual, multiple oil-disc	
Brakes, Secondary	air actuated, oil-disc	

All-Wheel Drive System

Pump output (2500 rpm, 35000 kPa)	175 L/min	46.2 gal/min
Maximum operating pressure	35 000 kPa	5,080 psi
Minimum operating pressure	5500 kPa	800 psi
Motor displacement - high	1650 cc/rev	100.7 in ³ /rev
Motor displacement - low	660 cc/rev	40.2 in ³ /rev

Hydraulic System

Circuit type	Closed center load sense	
Pump type	Axial piston	
Pump output @ 2100 RPM	206 L/min	54.4 gal/min
Maximum system pressure	24 150 kPa	3,500 psi
Reservoir tank capacity	38 L	9.9 gal
Standby pressure	3100 kPa	450 psi

Operating Specifications

Top Speed - Fwd.	44 kph	27.4 mph
- Rev.	34.7 kph	21.6 mph
Turning radius (outside front tires)	7.5 m	24.6 ft
Steering Range - left/right	50°	
Articulation Angle - left/right	20°	
Fwd. 1st	3.8 kph	2.3 mph
2nd	5.1 kph	3.2 mph
3rd	7.4 kph	4.6 mph
4th	10.3 kph	6.4 mph
5th	16.2 kph	10 mph
6th	22 kph	13.7 mph
7th	30.3 kph	18.8 mph
8th	44 kph	27.4 mph
Rev. 1st	3 kph	1.8 mph
2nd	5.6 kph	3.5 mph
3rd	8.1 kph	5 mph
4th	12.8 kph	7.9 mph
5th	23.9 kph	14.8 mph
6th	34.7 kph	21.6 mph

Service Refill

Fuel Tank	397 L	105 gal
Cooling system	38 L	10 gal
Hydraulic system - total	80 L	20.8 gal
- tank	38 L	9.9 gal
Engine oil	39 L	10.2 gal
Differential / Final Drives	47 L	12.4 gal
Tandem housing (each)	64 L	16.9 gal
Front wheel spindle bearing housing	0.5 L	0.13 gal
Circle drive housing	7 L	1.8 gal

Frame

Circle - diameter	1530 mm	60.2 in
Circle - blade beam thickness	30 mm	1.2 in
Drawbar - height	127 mm	5 in
- thickness	76 mm	3 in
Front - top/bottom plate - width	305 mm	12 in
- thickness	25 mm	1 in
Front - side plates - width	241 mm	9.5 in
- thickness	12 mm	0.5 in
Front - linear weights - min	165 kg/m	112 lb/ft
- max	213 kg/m	144 lb/ft
Front - section modulus - min	2083 cm ³	127 in ³
- max	4785 cm ³	291 in ³
Front axle - ground clearance	625 mm	24.6 in
- front wheel lean	18°	
- oscillation angle	32°	

Tandems

Height	572 mm	22.5 in
Width	201 mm	7.9 in
Sidewall thickness - inner	16 mm	0.63 in
- outer	18 mm	0.71 in
Drive chain pitch	51 mm	2 in
Wheel axle spacing	1522 mm	60 in
Tandem oscillation - forward	15°	
- reverse	25°	

Moldboard

Blade Width	3.658 m	12 ft
Blade Height	610 mm	24 in
Blade Thickness	22 mm	0.87 in
Arc radius	413 mm	16.25 in
Throat clearance	120 mm	4.7 in
Cutting edge - width	152 mm	6 in
- thickness	16 mm	0.63 in
End Bit - width	152 mm	6 in
- thickness	16 mm	0.63 in
Blade Pull - max GVW	19 931 kg	43,977 lb
- base GVW	13 743 kg	30,303 lb
Down Pressure - max GVW	13 665 kg	30,126 lb
- base GVW	7441 kg	16,400 lb

- Blade pull calculated at 0.9 traction coefficient, which is equal to ideal no-slip conditions, and Gross Vehicle Weight (GVW).

Blade Range

Circle centershift - right	728 mm	28.7 in
- left	695 mm	27.4 in
Moldboard sideshift - right	660 mm	26 in
- left	524 mm	20.6 in
Maximum blade position angle	90°	
Blade tip range (forward)	40°	
(backward)	5°	
Maximum shoulder reach outside of tires - right	1978 mm	77.9 in
- left	1896 mm	74.6 in
Maximum lift above ground	480 mm	18.9 in
Maximum depth of cut	715 mm	28.1 in

Ripper

Ripping depth, maximum	462 mm	18.2 in
Ripper shank holders	5	
Ripper shank holder spacing	533 mm	21 in
Penetration force	8047 kg	17,740 lb
Pryout force	9281 kg	20,460 lb
Machine length increase, beam raised	970 mm	38.2 in

Scarifier

Front, V-Type: Working width	1184 mm	46.6 in
Scarifying depth, maximum	292 mm	11.5 in
Scarifier shank holders	11	
Scarifier shank holder spacing	116 mm	4.6 in
Front, straight: Working width	1800 mm	71 in
Scarifying depth, maximum	317 mm	12.5 in
Scarifier shank holders	17	
Scarifier shank holder spacing	111 mm	4.38 in
Rear: Working width	2300 mm	91 in
Ripping depth, maximum	411 mm	16.2 in
Scarifier shank holders	9	
Scarifier shank holder spacing	267 mm	10.5 in

Weights

Gross Vehicle Weight - max	22 146 kg	48,863 lb
front axles	7906 kg	17,443 lb
rear axles	14 240 kg	31,420 lb
Gross Vehicle Weight - base	15 270 kg	33,670 lb
front axles	4305 kg	9,493 lb
rear axles	10 965 kg	24,177 lb

- Base operating weight calculated on standard machine configuration with 14.00-24 10PR (G-2) tires, full fuel tank, coolant, lubricants, and operator.

Cab

- ROPS (Rollover Protective Structure) meets the following criteria: SAE J1040 MAY 94, ISO 3471:1986, ISO 3471:1994
- FOPS (Falling Object Protective Structure) meets the following criteria: ISO 3449:1984, ISO 3449:1992 Level II

Brakes

- Brakes meet the following standard: SAE J/ISO 3450 JAN 98.

Dimensions

All dimensions are approximate. Based on standard machine configuration with 14.00-24 10PR tires.

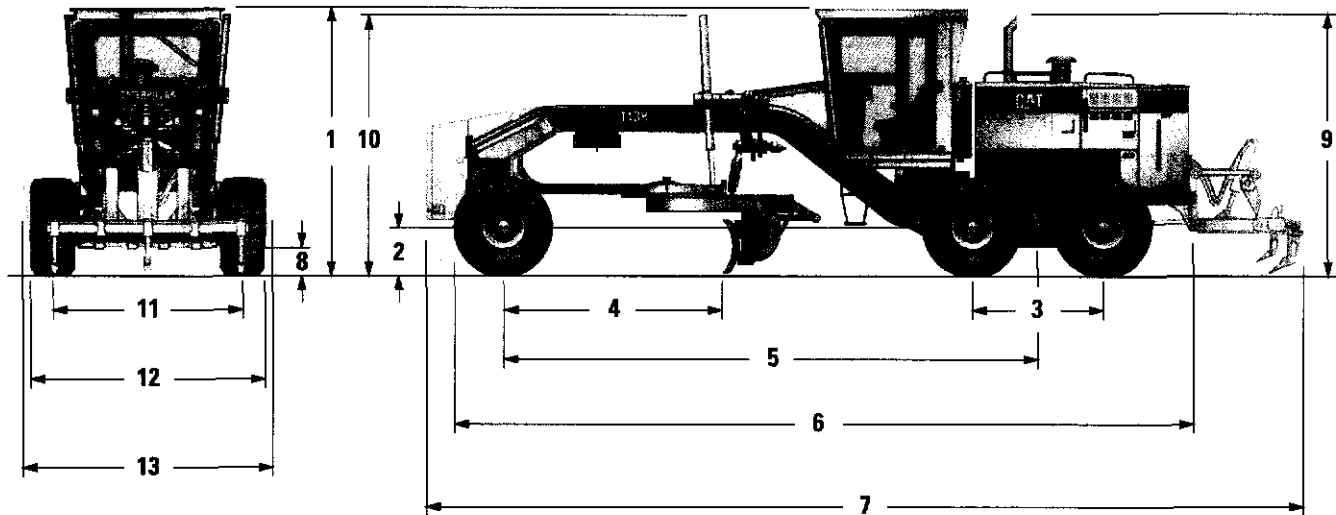

1	Height - low profile cab	3131 mm	123 in
	- high profile cab	3356 mm	132 in
	- no cab	3103 mm	122.2 in
2	Height to axle	600 mm	23.6 in
3	Length - between tandem axles	1523 mm	60 in
4	Length - front axle to moldboard	2561 mm	100.8 in
5	Length - front axle to mid tandem	6169 mm	242.9 in
6	Length - front tire to end of rear frame	8713 mm	343 in

7	Length - counterweight to ripper	10 097 mm	398 in
8	Ground clearance at trans. case	344 mm	13.5 in
9	Height to exhaust stack	3103 mm	122.2 in
10	Height to top of cylinders	3028 mm	119.2 in
11	Width - tire center lines	2091 mm	82.3 in
12	Width - outside rear tires	2457 mm	96.7 in
13	Width - outside front tires	2553 mm	100.5 in