



# 555 LOADER

## FEATURES

- 72 SAE net hp (53.7 kW)
- Single-lever loader control
- Full Power Shift transmission with torque converter
- Sealed track links
- Sealed track rollers and idlers
- Hydraulic track adjustment
- Self-adjusting, oil-cooled steering clutches and brakes
- Pedal steering
- Roll-over protective structure (ROPS)
- Vandal protection

## ADD VERSATILITY WITH:

- Winch
- Fairlead and drawbar
- Integral log arch
- Ripper
- Backhoe
- Log and Lumber fork
- Multipurpose bucket



## ENGINE PERFORMANCE

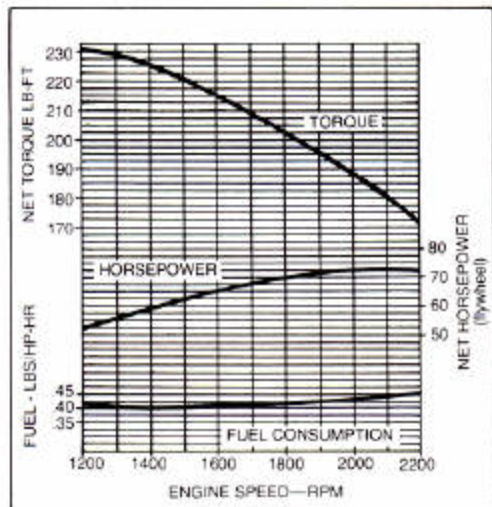

## LOADER SPECIFICATIONS

Buckets:	SAE Heaped Capacity	Width
Digging	1½ cu. yd. (0.96 m <sup>3</sup> )	72.25 in. (1.84 m)
Multipurpose	1¼ cu. yd. (0.96 m <sup>3</sup> )	73 in. (1.85 m)

### Operating Information:

Breakout force	15,750 lb. (70.59 kN) (7144 kg)
SAE tipping load	10,600 lb. (4808 kg)
Maximum dumping angle	50 deg.
Raising time	7.0 sec.
Dumping time	1.6 sec.
Lowering time	4.0 sec.

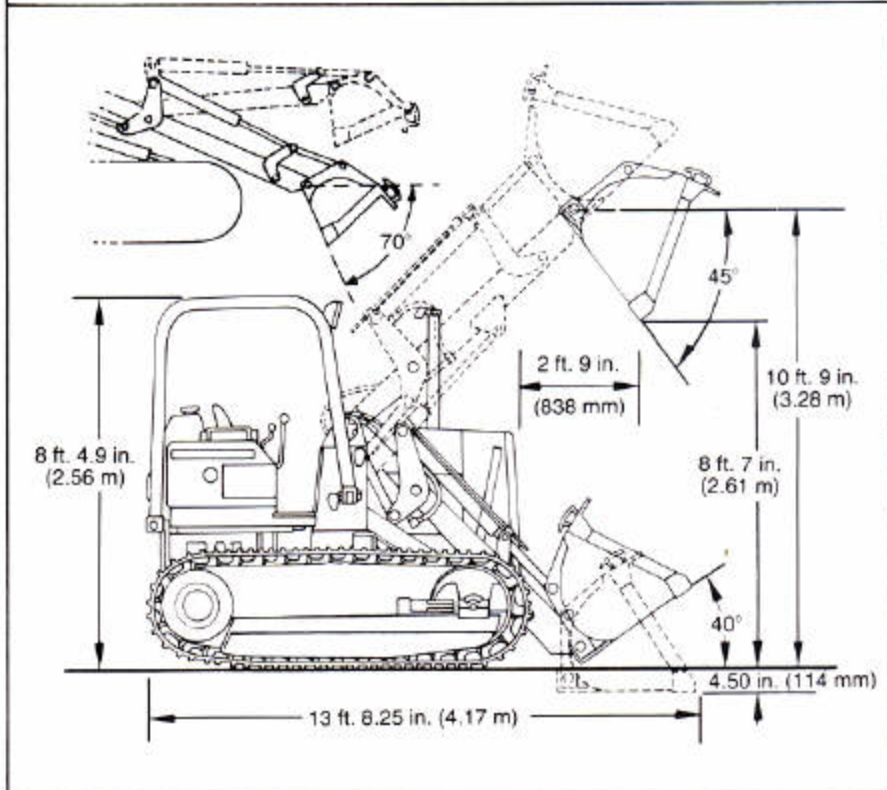

## 555 LOADER SPECIFICATIONS

(Specifications and design subject to change without notice. Wherever applicable, specifications are in accordance with ICED and SAE Standards. Except where otherwise noted, these specifications are based on a unit equipped with 1 1/2 cu. yd. (0.96 m<sup>3</sup>) digging bucket w/teeth, roll-over protective structure, and standard equipment.)

<b>Power (@ 2200 engine rpm):</b>	<b>SAE</b>	<b>DIN</b>
Gross .....	80 hp (59.7 kW)	
Net .....	72 hp (53.7 kW)	73 PS

Net engine flywheel power is for an engine equipped with fan, air cleaner, water pump, lubricating oil pump, fuel pump, alternator and muffler. The gross engine power is without fan. Flywheel power ratings are under SAE standard conditions of 500-ft. altitude and 85° F. temperature, and DIN 6270 conditions (non-corrected). No derating is required up to 10,000 feet (3000 m) altitude.

**Engine:** John Deere 4-cylinder turbocharged diesel, 4-stroke cycle  
 Bore and stroke ..... 4.19×5.00 in. (106.4×127 mm)  
 Piston displacement ..... 276 cu. in. (4.524 L)  
 Compression ratio ..... 16.2 to 1  
 Maximum torque @ 1200 rpm ..... 230 lb-ft (313 Nm) (31.8 kg-m)  
 Torque rise ..... 34 percent  
 NACC or AMA (U.S. Tax) horsepower ..... 28  
 Lubrication ..... Pressure system w/full-flow filter and cooler  
 Main bearings ..... 5  
 Cooling ..... Pressurized w/dual thermostat and controlled bypass  
 Fan ..... Blower  
 Air cleaner w/restriction indicator ..... Dry  
 Electrical system ..... 12-volt  
 Battery (12 volt) ..... Reserve capacity: 180 minutes

**Transmission** ..... Converter-driven, 3-speed forward and reverse, Power Shift

<b>Range:</b>	<b>Travel Speeds:</b>			
	<b>mph</b>		<b>km/h</b>	
	<b>Fwd.</b>	<b>Rev.</b>	<b>Fwd.</b>	<b>Rev.</b>
1	2.01	2.42	3.23	3.89
2	3.26	3.90	5.25	6.28
3	5.63	6.75	9.06	10.86

### Steering:

Steering clutches and brakes are controlled by a single pedal for each track. A separate pedal provides braking and lock-down for parking.  
 Clutches ..... Oil-cooled, hydraulically-actuated, multiple-disk, 11-in. (279 mm) disks; 16 friction surfaces per clutch.  
 Brakes ..... Self-adjusting, self-energizing, oil-cooled contracting band with bonded lining.

### Hydraulic System:

Control ..... Triple hydraulic valve with single-lever bucket control and third function control.  
 Pump ..... Gear, 28 gpm (1.76 L/s)  
 Pressure ..... 2250 psi (15 514 kPa) (158.2 kg/cm<sup>2</sup>)  
 Oil lines ..... Seamless steel tubing; double-wire-braid hose  
 Filter ..... Micronic in return line

<b>Hydraulic Cylinders:</b>	<b>Bore</b>	<b>Stroke</b>
Boom, (2) .....	4.25 in. (108 mm)	28.25 in. (718 mm)
Bucket, (2) .....	3.5 in. (89 mm)	31.1 in. (790 mm)
Cylinder rods .....	Ground, heat-treated, chrome-plated, polished	
Boom cylinder rods .....	2.25-in. (57 mm) dia.	
Bucket cylinder rods .....	1.75-in. (44.5 mm) dia.	

### Special Equipment:

13-inch (330 mm) rubber shoes  
 ROPS cab  
 Two batteries  
 Rear counterweight for multipurpose bucket  
 Winch drive  
 Limb risers w/overhead exhaust  
 Brush screens

### Tracks (5-roller track frames w/rock guards):

Triple semi-grouser, open center .....	14 in. (356 mm)
Track shoes, each side .....	37
Ground contact area .....	2128 sq. in. (13 729 cm <sup>2</sup> )
Ground pressure .....	8.2 psi (56.5 kPa) (0.576 kg/cm <sup>2</sup> )
Length of track on ground .....	76 in. (1.93 m)
Track gauge .....	52 in. (1.32 m)
Carrier roller .....	1
Adjustment .....	Hydraulic
Clearance at rear crossbar .....	14.25 in. (362 mm)

### Capacities:

	<b>U.S.</b>	<b>Imp.</b>	<b>Liters</b>
Cooling system .....	5 gal.	4.2 gal.	18.9
Fuel tank .....	36 gal.	30.0 gal.	136.3
Crankcase, including filter .....	15 qt.	12.5 qt.	14.2
Transmission .....	13.5 gal.	11.3 gal.	51.1
Final drive (each) .....	6.25 qt.	5.2 qt.	5.9
Loader hydraulic reservoir .....	7 gal.	5.8 gal.	26.5
Loader hydraulic system .....	13 gal.	10.8 gal.	49.2
Steering clutch housing (each side) .....	28 qt.	23.3 qt.	26.5

### Additional Standard Equipment:

Enclosed alternator w/solid state regulator  
 Front bottom guard  
 Front hitch  
 Cushion seat w/arm rests  
 Key switch  
 Push-button start  
 Precleaner  
 Electric hourmeter  
 Cigaret lighter  
 Vandal protection  
 Bottom guard counterweight  
 w/ fixed drawbar  
 Bucket level indicator  
 Radiator sand shield  
 Sprocket weights  
 Lights  
 Perforated engine side shields  
 Boom safety lock bar  
 Muffler  
 Tachometer  
 Ether starting aid  
 Front idler shields  
 Master electrical disconnect switch  
 Return to dig  
 Rubber-mounted ROPS w/seat belt  
 Decelerator  
 Horn

**SAE Operating Weight w/ROPS** ..... 18,255 lb. (8280.5 kg)