

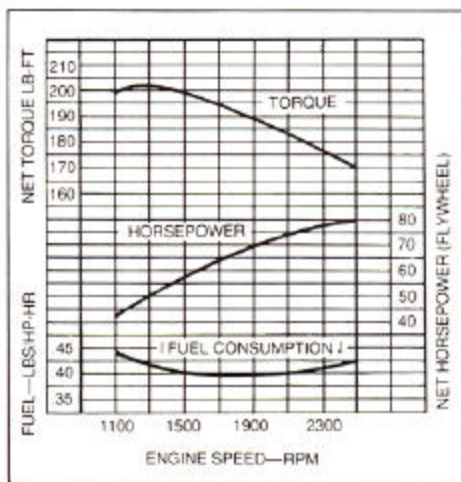

500C BACKHOE LOADER



ENGINE PERFORMANCE



FEATURES

- 80 SAE net hp (59.7 kW)
- Backhoe digging depth (ICED) 15 ft. (4.57 m)
- Power shift transmission
- Self-adjusting wet-disk power brakes
- Inboard planetary final drives
- Roll-over protective structure (ROPS)
- Choice of 2 self-leveling loader buckets
- Single-lever loader control
- Single, swing-around seat
- Two-lever backhoe control
- Choice of 10 backhoe buckets
- Extendable dipperstick available
- Power Steering

TED B. MILLER CO., INC.
GERING, NEB.

500C BACKHOE LOADER SPECIFICATIONS

(Specifications and design subject to change without notice. Wherever applicable, specifications are in accordance with ICEO and SAE Standards. Except where otherwise noted, these specifications are based on a unit equipped with 18.4-28, 8-ply-rating rear tires; 14.5/75-16, 10-ply-rating front tires; 1 cu. yd. (0.76 m³) loader bucket, 24 in. (610 mm) standard backhoe bucket and standard equipment.)

Power (@ 2500 engine rpm):	SAE	DIN
Gross	83 hp (61.9 kW)	
Net	80 hp (59.7 kW)	85.0 PS

Net engine flywheel power is for an engine equipped with fan, air cleaner, water pump, lubricating oil pump, fuel pump, alternator, and muffler. Gross engine power is without fan. Flywheel power ratings are under SAE standard conditions of 900 ft. altitude and 85 F. temperature and DIN 70 020 standard conditions of 760 mm Hg barometer (sea level) and 20 C temperature.

Engine: John Deere diesel, 4-cylinder, 4-stroke cycle	
Bore and stroke	4.25 x 4.75 in. (108 x 121 mm)
Piston displacement	270 cu. in. (4.425 L)
Compression ratio	17.3 to 1
Maximum torque @ 1300 rpm	202 lb-ft (274 Nm) (27.9 kg-m)
NACC or AMA (U.S. Tax) horsepower	28.9
Main bearings	5
Lubrication	Pressure system w/full-flow filter
Cooling	Pressurized w/thermostat and fixed bypass
Fan	Suction
Air cleaner w/restriction indicator	Dry
Electrical system	12-volt w/alternator
Batteries (two 6 volt)	Reserve capacity: 340 minutes each

Transmission:

Full power shift, 8 speeds forward, 4 reverse. Power shift from forward to reverse in first 4 gears.

Gear:	Travel Speeds		
	mph	km/h	
Forward	1	1.7	2.7
	2	2.4	3.9
	3	3.8	6.1
	4	4.9	7.9
	5	6.3	10.1
	6	8.1	13.0
	7	10.8	17.4
	8	18.0	29.0
Reverse	1	2.0	3.2
	2	2.8	4.5
	3	4.4	7.1
	4	5.7	9.2

Final Drives Inboard, planetary

Brakes Hydraulically power actuated, fully enclosed wet-disk. Self-equalizing. Foot-operated individually or simultaneously.

Steering: Power

Turning radius (brake applied)	11 ft. 2 in. (3.40 m)
Loader clearance (brake applied)	33 ft. (10.06 m)
Number of turns, far left to far right	5

Hydraulic System: Closed-center

Pressure	2350 psi (16 203 kPa) (165.2 kg/cm ²)
Loader control	Single-lever
Backhoe control	Two-lever
Pump	Piston, constant pressure, variable-displacement
38 gpm (2.4 L/s) @ 2500 engine rpm	
Filter	25-micron steel-enclosed paper cartridge in return

Hydraulic Cylinders:	Bore	Stroke
Loader boom	3.25 in. (83 mm)	28.7 in. (729 mm)
Loader bucket	3.25 in. (83 mm)	16.7 in. (424 mm)
Backhoe boom	4.5 in. (114 mm)	36.7 in. (932 mm)
Backhoe crowd	4.5 in. (114 mm)	35.5 in. (902 mm)
Backhoe bucket	3.5 in. (89 mm)	27.37 in. (695 mm)
Backhoe swing	4 in. (102 mm)	9.31 in. (237 mm)
Stabilizer	3.5 in. (89 mm)	16.9 in. (429 mm)

Cylinder rods	Ground, heat-treated, chrome-plated, polished
Loader boom, backhoe swing and stabilizer cylinder rods	1.75-in. (44 mm) dia.
Loader bucket cylinder rods	1.50-in. (38 mm) dia.
Backhoe crowd, boom and bucket cylinder rods	2.25-in. (57 mm) dia.

Tires:	Front	Rear
	14.5/75-16.1, 10-ply-rating, F3	18.4-28, 8-ply-rating, R4
		18.4-28, 12-ply-rating, R4

Wheel Treads:

Front	66 in. (1.68 m)
Rear	65.5 in. (1.66 m)

Capacities:	U.S.	Imp.	Liters
Cooling system	4.75 gal.	4.0 gal.	18.0
Fuel tank	34 gal.	28.3 gal.	128.7
Engine lubrication, including filter	8 qt.	6.7 qt.	7.6
Transmission and hydraulic system	21.5 gal.	18.0 gal.	81.4

OPERATING INFORMATION

LOADER:

Rollback at ground level	40 deg.
Breakout force	7800 lb. (34.96 kN) (3538 kg)
Digging depth below ground level (with bucket level)	1 in. (25 mm)
Lifting capacity, full height	5300 lb. (2404 kg)
Height to bucket hinge pin	10 ft. 9 in. (3.28 m)
Maximum dump angle	60 deg.
Clearance, bucket dumped at 45 degrees	8 ft. 6 in. (2.59 m)
Reach at maximum height, bucket dumped at 45 degrees	2 ft. 10 in. (864 mm)
Raising time to full height	4.5 sec.
Bucket dump time	1.5 sec.
Lowering time (power)	3.0 sec.

BACKHOE:

Digging depth (ICED):	
Maximum	15 ft. 1 in. (4.60 m)
2-ft. (610 mm) flat bottom	15 ft. (4.57 m)
8-ft. (2.44 m) flat bottom	14 ft. (4.27 m)
Swing arc	180 deg.
Lifting capacity:	
Boom at full reach and full height	1950 lb. (884 kg)
Dipper lifting, boom holding, full height	3300 lb. (1497 kg)
Digging force (bucket cylinder in power-dig position)	
	9650 lb. (43.25 kN) (4377 kg)
Digging force, crowd cylinder	
	7158 lb. (32.08 kN) (3247 kg)
Reach from center of swing mast	18 ft. 7 in. (5.66 m)
Reach from center of rear axle	22 ft. 1 in. (6.73 m)
Loading height (truck-loading position)	11 ft. 8 in. (3.56 m)
Transport height	11 ft. 8 in. (3.56 m)
Bucket rotation	Adjustable for 123, 126, or 154 deg.
Bucket position	Adjustable for 22 or 13 deg. rollback and 2 deg. forward

Stabilizer Width:

Transport position	7 ft. 3 in. (2.21 m)
Operating position (overall)	10 ft. 2 in. (3.10 m)
Operating position (ICED)	8 ft. 9 in. (2.67 m)

Buckets:

	Nominal Heaped Capacity	Width
LOADER		
General Purpose	1 cu. yd. (0.76 m ³)	89.4 in. (2.27 m)
Light Materials	1 1/4 cu. yd. (0.96 m ³)	89.4 in. (2.27 m)
BACKHOE	Struck Capacity	Width
Standard	2.5 cu. ft. (0.071 m ³)	12 in. (305 mm)
	3.6 cu. ft. (0.102 m ³)	16 in. (406 mm)
	4.4 cu. ft. (0.125 m ³)	18 in. (457 mm)
	6.0 cu. ft. (0.170 m ³)	24 in. (610 mm)
	7.6 cu. ft. (0.215 m ³)	30 in. (762 mm)
	7.2 cu. ft. (0.204 m ³)	36 in. (914 mm)
Heavy-duty	4.4 cu. ft. (0.125 m ³)	18 in. (457 mm)
	6.0 cu. ft. (0.170 m ³)	24 in. (610 mm)
	7.6 cu. ft. (0.215 m ³)	30 in. (762 mm)
Ejector	4.2 cu. ft. (0.119 m ³)	24 in. (610 mm)

500C BACKHOE LOADER DIMENSIONS

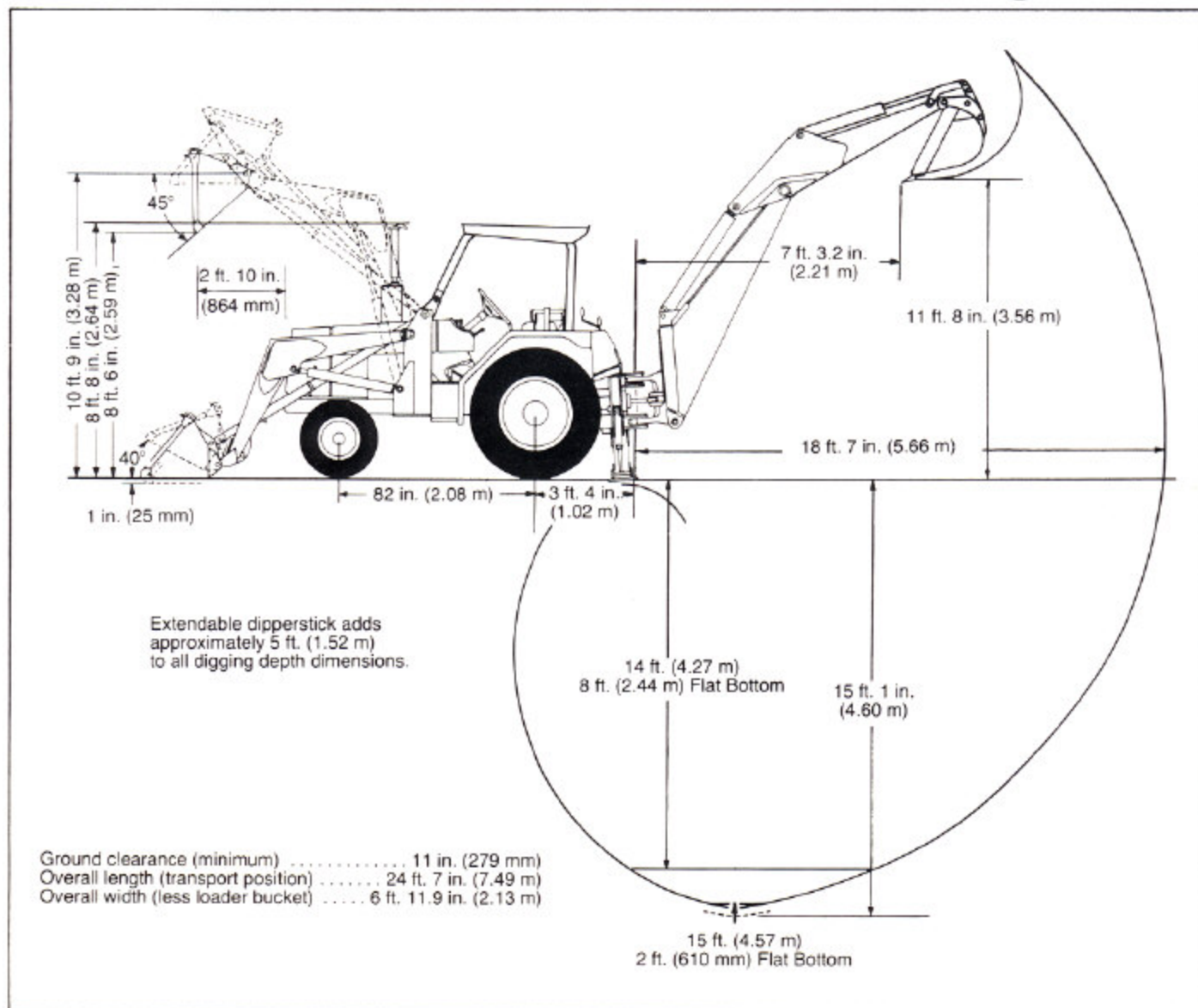

Additional Standard Equipment:

Differential lock
 Vertical muffler w/rain cap
 Fuel gauge
 Oil pressure indicator light
 Alternator charge indicator light
 Water temperature gauge
 Trans. lube pressure indicator light
 Flat deck w/skid-proof platform
 Rear reflector
 Transistorized voltage regulator
 Key switch w/push-button safety start
 Lights

Ether starting aid
 Fenders
 Horn
 Bucket level indicator
 Electric hourmeter
 Foot throttle
 Cigaret lighter
 Trans. temp. gauge
 Tachometer
 Hand throttle
 Antifreeze
 Deluxe swing-around seat
 Vandal protection
 ROPS w/canopy and seat belt

Special Equipment:

Exhaust extension
 Steel bucket teeth for loader
 Cab (includes ROPS, front windshield wiper, seat belt and exhaust extension)
 Cab pressurizer
 Cab heater
 Cab defroster
 24 in. (610 mm) ripper tooth for backhoe
 Bolt-on stabilizer street pads
 Extendable dipperstick
 Parking brake
 Reversible stabilizer pads
 Backup alarm

SAE Operating Weight 16,063 lb. (7286 kg)