

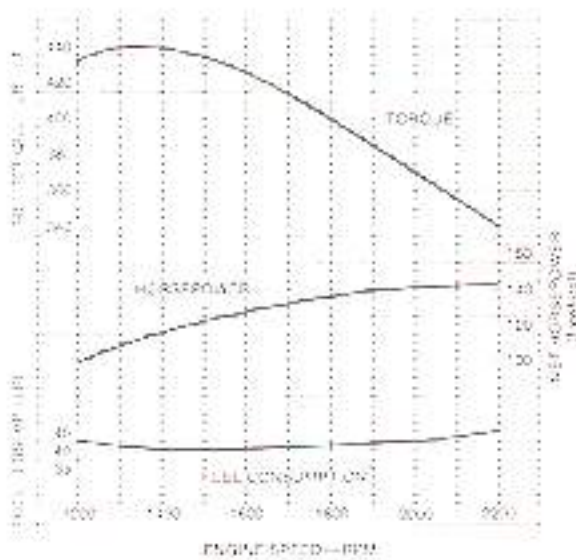

JD770 MOTOR GRADER



ENGINE PERFORMANCE



FEATURES

142 SAE net hp (144 PS)

12-ft. (3.66 m) blade standard; 13-ft. (3.96 m) and 14-ft. (4.27 m) blades and 2-ft. (610 mm) extensions available

Power Shift transmission;
8 speeds forward, 4 reverse

Articulated frame steering

Differential lock-unlock

22-ft. (6.71 m) turning radius

All-hydraulic control of blade and machine functions

Closed-center hydraulic system with no-leak, drift-free poppet valves

Push-button control

Hydraulically controlled, 7-position lift arms let you position blade for 90-degree bank cuts, left or right, in approximately one minute, without leaving the seat

Oscillating front axle and rear tandem

Hydraulic front-wheel lean

Roll-over protective structure (ROPS) w/cab

ADD VERSATILITY WITH:

Scarifier

Rear-mounted ripper

Snow plow and wings

Bulldozer

JD770 MOTOR GRADER SPECIFICATIONS

(Specifications and design subject to change without notice. Wherever applicable, specifications are in accordance with ICED and SAE Standards. Except where otherwise noted, these specifications are based on a unit equipped with 13.00-24, 10-ply rating, tubeless tires, 13-ft. (3.96 m) moldboard, and standard equipment.)

Power (at 2200 engine rpm): SAE
Gross 152 hp (113.5kW*)
Net 142 hp (106 kW) 144 PS

Net engine flywheel power is for an engine equipped with fan, air cleaner, water pump, lubricating oil pump, fuel pump, alternator, and muffler. The gross engine power is without fan. Flywheel power ratings are under SAE standard conditions of 500-ft. altitude and 85°F. temperature, and DIN 70 020 conditions (non-corrected). No derating is required up to 10,000 ft. (3000 m) altitude.

*In the international system of units (SI), power is expressed in kilowatts (kW).

Engine: John Deere Turbocharged diesel, vertical 6-cylinder, valve-in-head, 4-stroke cycle

Bore and stroke 4.75x5 in. (120.6x127 mm)
Piston displacement 531 cu. in. (8702 cm³)
Compression ratio 15.8 to 1
Maximum torque @ 1,400 rpm .. 440 lb-ft (597 Nm) (60.9 kg-m)
NACC or AMA (U.S. Tax) horsepower 54.15
Main bearings 7
Lubrication Pressure system w/full-flow filter
Cooling Pressurized w/thermostat and fixed bypass
Fan Suction
Air cleaner w/restriction indicator Dry
Electrical system 24-volt w/alternator
Batteries (2) Reserve capacity: 360 minutes

Transmission .. Power Shift, 8 forward and 4 reverse selections

Differential Lock Foot-operated, hydraulically actuated

Travel Speeds (2200 engine rpm, no tire slip, 14.00-24 tires):

Shift Lever Position	mph	km/h	
Forward	1	2.3	3.7
	2	3.3	5.3
	3	5.2	8.9
	4	6.7	10.8
	5	8.8	14.2
	6	11.5	18.5
	7	14.6	23.6
	8	25.1	40.4
Reverse	1	3.0	4.8
	2	4.2	6.8
	3	6.6	10.6
	4	8.6	13.9

Final Drives Inboard planetary

Brakes:
Service Foot-operated, hydraulically actuated, wet-disk, effective on 4 tandem wheels
Parking Foot-operated, mechanical, dry-disk, effective on 4 tandem wheels

Steering:
Front Full hydraulic power system
Range 47.5 deg, left or right
Rear Hydraulically articulated frame steering (25 deg, left or right)
Turning radius 22 ft. (6.71 m)

Hydraulic System: Closed-center
Standby pressure 2250 psi (155.1 bar) (158.2 kg/cm²)
Pump Variable-displacement, 57 gpm (216 l/min) @ 2200 engine rpm

Circle: 5 ft. (1.5 m) dia., welded angle
Rotation 360 deg.
Drive Hydraulic motor and worm gear

Drawbar Welded box, 3.5x7x0.5 in. (89x178x13 mm) wall, w/ball and socket pivot

Blade:
Length 12 ft. (3.66 m)
Height 24 in. (610 mm)
Thickness 0.88 in. (22 mm)

Blade Lifting Mechanism:
Control Dual-lever, hydraulic
Cylinders (2) .. 3.5 in. (89 mm) dia. bore; 49 in. (1.25 m) stroke

Blade Range:
Lift above ground 1 ft. 5 in. (432 mm)
Blade side shift:
Right or left 2 ft. 2.9 in. (683 mm)
Shoulder reach outside wheels:
Right 7 ft. 8.5 in. (2.35 m)
Left 7 ft. 8 in. (2.34 m)
Pitch 35 deg. total

Lift Arms:
Positions 7
Control Hydraulic, foot operated

Frame:
Rear mainframe .. Flanged box section from articulation joint to mainframe arch
Top and bottom plate, width 14 in. (356 mm)
thickness 0.875 in. (22 mm)
Side plates, minimum height 10.25 in. (260 mm)
thickness 0.50 in. (13 mm)
Weight per ft., min. 112 lb. (166.7 kg/m)
Minimum vertical-section modulus 127 inches cubed (323 cm cubed)
Front mainframe Formed box section from mainframe arch to front hood
Width 10 in. (254 mm)
Height, min. 13 in. (330 mm)
Thickness 0.625 in. (16 mm)
Weight per ft. (m), min. 92.3 lb. (137.3 kg/m)
Minimum vertical section modulus 100 inches cubed (254 cm cubed)

Tandems: Welded steel box section, 27x7.56 in. (686x192 mm)
Drive 2 in. (50.8 mm) pitch roller chain
Axle dia. at bearings 3.63 in. (92 mm)
3.35 in. (85 mm)

Front Axle: Fabricated steel box-frame with steel spindles, tapered roller bearings
Diameter at bearing seats 3.54 in. (90 mm)
1.87 in. (48 mm)
Total oscillation 30 deg.
Wheel lean (either direction) 20 deg.

Rear Drive Axle: Full floating with tapered roller bearings
Diameter at bearings 3.63 in. (92.2 mm)

Tires
 13.00-24, 10- or 12-ply rating; 8-in. rim
 14.00-24, 10- or 12-ply rating; 8- or 10-in. rim
 17.5-25, 12-ply rating; 14-in. rim

Dimensions:

Tire Size	Wheel Tread		Width		Ground Clearance (Front Axle)
	Front	Rear	Front	Rear	
13.00-24	76.60 in. (1.94 m)	79.61 in. (2.02 m)	7 ft. 10 in. (2.34 m)	7 ft. 10 in. (2.34 m)	1 ft. 10 in. (559 mm)
14.00-24	76.60 in. (1.94 m)	79.61 in. (2.02 m)	8 ft. (2.44 m)	8 ft. (2.44 m)	1 ft. 10.5 in. (571 mm)
17.5-25	79.36 in. (2.01 m)	82.37 in. (2.08 m)	8 ft. 6 in. (2.59 m)	8 ft. 6 in. (2.59 m)	1 ft. 11.2 in. (589 mm)

Height to top of steering wheel 7 ft. 6 in. (2.29 m)

Capacities

	U.S.	Liters
Fuel tank	70 gal.	265.0
Cooling system	10 gal.	37.9
Engine lubrication, including filter	22 qt.	20.8
Transmission and hydraulic system	31 gal.	117.3
Tandem housings (each)	4 gal.	15.1
Worm gearbox	3 qt.	2.8

JD770 MOTOR GRADER DIMENSIONS

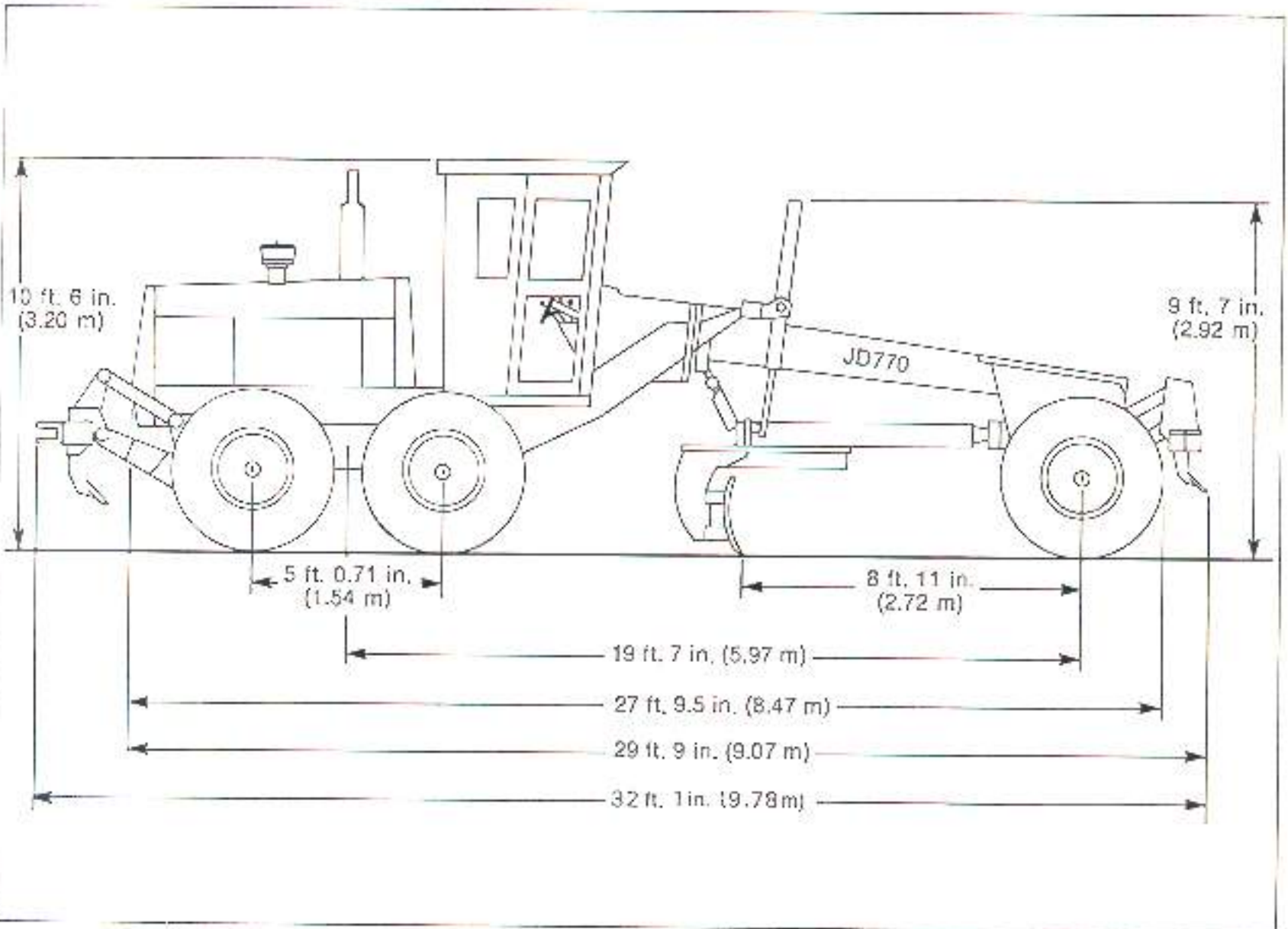

Scarifier (Special Equipment):
 V-type for 4 ft. (1.22 m) cut with 3 manual pitch positions and hydraulic float
 Number of teeth (9 possible) 5
 Lift above ground 1 ft. 10 in. (559 mm)
 Penetration 12 in. (305 mm)
 Shank size 1.25x4 in. (31.7x102 mm)

Ripper (Special Equipment): 8 ft. (2.44 m) cut width, parallelogram linkage, 2 manual shank vertical positions
 Number of shank pockets 5
 Number of shanks 3
 Lift above ground 1 ft. 2.5 in. (368 mm)
 Penetration 1 ft. 2 in. (356 mm)
 Shank size 2x5 in. (51x127 mm)
 Lift above ground (shank in upper position) 1 ft. 11.5 in. (397 mm)

SAE Operating Weight	On Front Wheels	On Rear Wheels	Total
Standard equipment . . .	8040 lb. (3647 kg)	21,420 lb. (9716 kg)	29,460 lb. (13,363 kg)
Standard equipment, and scarifier	9254 lb. (4197 kg)	21,420 lb. (9716 kg)	30,674 lb. (13,913 kg)
Standard equipment, scarifier and ripper . . .	8457 lb. (3836 kg)	24,717 lb. (11,211 kg)	33,174 lb. (15,047 kg)

Additional Standard Equipment:
 Transistorized voltage regulator
 Lights (2 white front w/stop and taillight)
 Work lights (2 front and 2 rear floods)
 Turn signals
 Cigaret lighter
 Horn
 Deluxe seat
 Air filter indicator
 Mechanical hourmeter
 Ether starting aid

Gauges:
 Water temperature
 Transmission temperature
 Transmission lube
 Transmission pressure
 Engine oil pressure
 Fuel gauge
 Precleaner
 ROPS cab w/seat belt
 Front windshield wiper
 Rear windshield wiper
 Floor mat
 Engine side-shields

Special Equipment:
 Scarifier
 Below-cab blade lights
 Bench seat
 Cab heater
 Cab defroster fan
 ROPS canopy w/seat belt
 Coolant heater
 2-ft. (610 mm) moldboard extensions, right or left
 13-ft. (3.96 m) and 14-ft. (4.27 m) moldboards
 Overlay end bits
 Transmission bottom guard

Moldboard float position
 Rear-mounted ripper w/drawbar hitch
 Heavy-duty batteries (620 min. reserve capacity)
 Drawbar hitch
 Toolbox
 Articulation indicator
 Engine disconnect
 Reverse warning system
 Sound baffled engine side shields
 3-in seat belt
 Heavy-duty cutting edge