



# 190E

## EXCAVATOR



Model shown may include options

**SAE Net  
Horsepower**

55 hp  
(41 kW)

**Digging  
Depth**

15 ft., 3 in.  
(4.7 m)

**Operating  
Weight**

16,300 lb.  
(7394 kg)



## QUADTRONICS

State-of-the-art technology simplifies your job. Engine speed can be adjusted with the power mode buttons or by using the throttle buttons. QUADTRONICS lets you easily tailor machine output to the job, delivers more efficient production and uses less fuel. It's simply the best engine/hydraulic management system available today.



## HYDRAULIC CONTROLS

Controls are conveniently located and are pilot operated for low effort, precise metering and smooth operation. When a hydraulic function is not used for four seconds the 190E's auto idle feature reduces the engine speed to 1300 rpm to save fuel. As soon as a control lever is moved, the engine automatically resumes its preselected speed. Touch the button on top of the left control lever to activate the horn.



## ELECTRONIC CONTROLS

This panel puts control of the 190E at your fingertips. Adjust engine speed with a simple touch of one of the top buttons or select any of four pre-selected speeds with one of the four buttons below. The hydraulic warm-up modes and the auto idle are also controlled by the touch of a button. Select any of three travel speeds by touching one of the bottom buttons.











## PROPEL









Two high-torque axial piston propel motors, positioned inside the track shoe width, and planetary reduction gearing provide drawbar pull of 10,360 lb. (46.0 kN) and a top speed of 3.1 mph (5.0 km/h). An independent drive to each track allows counterrotation for excellent maneuverability in tight quarters. A generous 15 inches (360 mm) of ground clearance lets the 190E work effectively in even the most adverse conditions.









# LIFT C. PACITIES









Ratings at bucket lift hook, machine equipped with 18-in. (450 mm) shoes, 0.36-cu. yd. (0.28 m<sup>3</sup>) 50-in. (760 mm) wide bucket and situated on firm, uniform supporting surface. Total load includes weight of cables, hook, etc. **Boldface** type indicates hydraulic-limited capacities, lightface type indicates stability-limited capacities, in lb. (kg). Figures do not exceed 87 percent of hydraulic capacities or 75 percent of weight needed to tip machine.









 OVER FRONT  OVER SIDE









With standard one-piece boom, 5 ft. (1.52 m) arm, and no blade	Load Point Height	 5 ft. (1.52 m) 	 10 ft. (3.05 m) 	 15 ft. (4.57 m) 	 20 ft. (6.10 m) 
	15 ft. (4.57 m)			<b>2,668 (1210)</b>	<b>2,668 (1210)</b>
10 ft. (3.05 m)			<b>3,845 (1744)</b>	<b>3,845 (1744)</b>	<b>2,971 (1348)</b>
5 ft. (1.52 m)			5,336 (2420)	4,432 (2010)	2,808 (1274)
Ground Line			5,031 (2282)	4,146 (1880)	2,667 (1210)
-5 ft. (-1.52 m)	<b>7,758 (3519)</b>	<b>7,758 (3519)</b>	5,010 (2273)	4,126 (1872)	2,631 (1193)
-10 ft. (-3.05 m)			<b>5,132 (2328)</b>	4,286 (1944)	

With standard one-piece boom, 6 ft. (1.82 m) arm, and no blade	Load Point Height	 5 ft. (1.52 m) 	 10 ft. (3.05 m) 	 15 ft. (4.57 m) 	 20 ft. (6.10 m) 
	15 ft. (4.57 m)				<b>2,638 (1197)</b>
10 ft. (3.05 m)			<b>3,009 (1365)</b>	<b>3,009 (1365)</b>	<b>2,909 (1320)</b>
5 ft. (1.52 m)			<b>5,493 (2492)</b>	4,618 (2095)	2,875 (1304)
Ground Line			5,102 (2314)	4,212 (1911)	2,704 (1227)
-5 ft. (-1.52 m)	<b>6,483 (2941)</b>	<b>6,483 (2940)</b>	4,998 (2267)	4,115 (1867)	2,627 (1192)
-10 ft. (-3.05 m)	<b>10,405 (4720)</b>	<b>10,405 (4720)</b>	5,090 (2309)	4,201 (1906)	

With offset boom, 5 ft. 4 in. (1.62 m) arm, and no blade	Load Point Height	 5 ft. (1.52 m) 	 10 ft. (3.05 m) 	 15 ft. (4.57 m) 	 20 ft. (6.10 m) 
	15 ft. (4.57 m)			<b>2,756 (1250)</b>	<b>2,756 (1250)</b>
10 ft. (3.05 m)			<b>3,803 (1725)</b>	<b>3,803 (1725)</b>	2,935 (1351)
5 ft. (1.52 m)				2,642 (1198)	2,183 (990)
Ground Line				2,589 (1084)	1,939 (880)
-5 ft. (-1.52 m)			4,468 (2027)	3,567 (1618)	2,518 (1051)
-10 ft. (-3.05 m)			<b>4,384 (1989)</b>	3,854 (1739)	

With standard one-piece boom, 5 ft. 4 in. (1.62 m) arm, and blade	Load Point Height	 5 ft. (1.52 m) 	 10 ft. (3.05 m) 	 15 ft. (4.57 m) 	 20 ft. (6.10 m) 
	15 ft. (4.57 m)			<b>2,668 (1210)</b>	<b>2,668 (1210)</b>
10 ft. (3.05 m)			<b>3,845 (1744)</b>	<b>3,845 (1744)</b>	3,084 (1399)
5 ft. (1.52 m)			5,536 (2511)	4,717 (2140)	2,920 (1324)
Ground Line			5,231 (2373)	4,430 (2009)	2,780 (1261)
-5 ft. (-1.52 m)	<b>7,758 (3519)</b>	<b>7,758 (3519)</b>	5,209 (2363)	4,411 (2001)	2,744 (1245)
-10 ft. (-3.05 m)			<b>5,132 (2328)</b>	4,571 (2073)	

With standard one-piece boom, 6 ft. 11 in. (2.12 m) arm, and blade	Load Point Height	 5 ft. (1.52 m) 	 10 ft. (3.05 m) 	 15 ft. (4.57 m) 	 20 ft. (6.10 m) 
	15 ft. (4.57 m)				<b>2,638 (1197)</b>
10 ft. (3.05 m)			<b>3,009 (1365)</b>	<b>3,009 (1365)</b>	<b>2,909 (1320)</b>
5 ft. (1.52 m)			<b>5,493 (2492)</b>	4,902 (2224)	2,987 (1355)
Ground Line			5,301 (2405)	4,496 (2039)	2,816 (1277)
-5 ft. (-1.52 m)	<b>6,483 (2941)</b>	<b>6,483 (2941)</b>	5,197 (2357)	4,399 (1995)	2,739 (1242)
-10 ft. (-3.05 m)	<b>10,405 (4720)</b>	<b>10,405 (4720)</b>	5,290 (2400)	4,486 (2035)	

With offset boom, 5 ft. 4 in. (1.62 m) arm, and no blade	Load Point Height	 5 ft. (1.52 m) 	 10 ft. (3.05 m) 	 15 ft. (4.57 m) 	 20 ft. (6.10 m) 
	15 ft. (4.57 m)			<b>2,756 (1250)</b>	<b>2,756 (1250)</b>
10 ft. (3.05 m)			<b>3,803 (1725)</b>	<b>3,803 (1725)</b>	3,048 (1383)
5 ft. (1.52 m)				2,755 (1250)	2,349 (1066)
Ground Line				2,502 (1135)	2,105 (955)
-5 ft. (-1.52 m)			4,667 (2117)	3,851 (1747)	2,451 (1103)
-10 ft. (-3.05 m)			<b>4,384 (1989)</b>	4,119 (1868)	

# OPERATING INFORMATION

	<b>5 ft. 4 in.</b> <b>(1.62 m)</b>	<b>6 ft. 11 in.</b> <b>(2.12 m)</b>
	<b>Arm Length</b>	<b>Arm Length</b>
Arm force with 30-in. (760 mm) heavy-duty bucket.....	8,500 lb. (37.8 kN)	7,190 lb. (32.0 kN)
Bucket tangential force with 30-in. (760 mm) heavy-duty bucket.....	11,185 lb. (49.8 kN)	11,185 lb. (49.8 kN)
Lifting capacity over front @ ground level 15-ft. (4.57 m) reach.....	2,780 lb. (1261 kg)	2,816 lb. (1277 kg)
A Maximum reach.....	20 ft. 8 in. (6.31 m)	22 ft. 4 in. (6.80 m)
A' Maximum reach @ ground level.....	20 ft. 3 in. (6.16 m)	21 ft. 10 in. (6.66 m)
B Maximum digging depth.....	13 ft. 7 in. (4.15 m)	15 ft. 3 in. (4.66 m)
B' Maximum digging depth @ 8 ft. (2.44 m) flat bottom.....	12 ft. 6 in. (3.8 m)	14 ft. 4 in. (4.37 m)
C Maximum cutting height.....	23 ft. 5 in. (7.15 m)	24 ft. 9 in. (7.55 m)
D Maximum dumping height.....	16 ft. 8 in. (5.07 m)	17 ft. 11 in. (5.47 m)
E Minimum front swing radius.....	5 ft. 7 in. (1.70 m)	6 ft. 9 in. (2.06 m)
F Minimum rear swing radius.....	5 ft. 9 in. (1.75 m)	5 ft. 9 in. (1.75 m)
G Maximum vertical wall.....	11 ft. 6 in. (3.50 m)	13 ft. 4 in. (4.06 m)

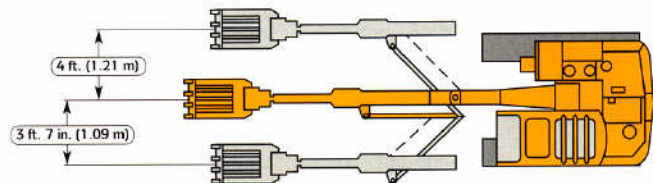
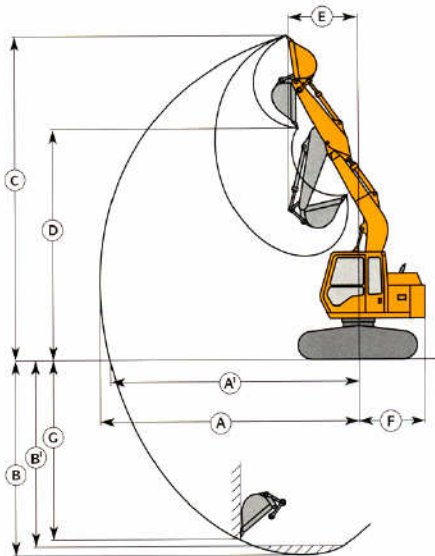

## Dimensions for offset boom with 5 ft. 4 in. (1.62 m) arm (not available with long arm):

	<b>With No Boom Offset</b>	<b>With Offset To Left 3 ft. 7 in. (1.09 m)</b>	<b>With Offset To Right 4 ft. 0 in. (1.21 m)</b>
Maximum digging depth.....	13 ft. 7 in. (4.15 m)	12 ft. 2 in. (3.70 m)	12 ft. 2 in. (3.70 m)
Maximum digging depth with 8 ft. (2.44 m) flat bottom.....	12 ft. 2 in. (3.70 m)	10 ft. 10 in. (3.31 m)	10 ft. 10 in. (3.31 m)
Maximum reach @ ground level.....	20 ft. 3 in. (6.16 m)	18 ft. 8 in. (5.70 m)	18 ft. 8 in. (5.70 m)
Maximum dumping height.....	16 ft. 8 in. (5.07 m)	15 ft. 6 in. (4.72 m)	15 ft. 6 in. (4.72 m)
Maximum cut outside of track with 18-in. (450 mm) shoes and 0.36 cu. yd. (0.28 m <sup>3</sup> ), 30 in. (750 mm) wide bucket.....	18.5 in. (470 mm)	21.5 in. (546 mm)	

\*Maximum digging depth will be less in applications where offset boom interferes with edge of trench.

# BUCKETS

A full line of buckets are offered to meet a wide variety of applications. All capacities are SAE heaped\* ratings. Tooth selection includes either the John Deere Fanggs® tooth or Tiger, Twin Tiger, Flare, Star or Long Rock tooth. Replaceable cutting edges are available through John Deere parts.

Type Bucket	Bucket Width		Bucket Capacity*		Weight		Bucket Dig Force		Arm Dig Force 5 ft. 4 in. (1.62 m)		Arm Dig Force 6 ft. 11 in. (2.12 m)		Bucket Tip Radius		No. Teeth
	in.	mm	yd. <sup>3</sup>	m <sup>3</sup>	lb.	kg	lb.	kN	lb.	kN	lb.	kN	in.	mm	
Heavy-Duty Plate Lip	18	460	0.18	0.14	376	171	11,185	49.8	8,500	37.8	7,190	32.0	39.0	991	4
	24	610	0.27	0.21	450	204	11,185	49.8	8,500	37.8	7,190	32.0	39.0	991	5
	30	760	0.36	0.28	462	210	11,185	49.8	8,500	37.8	7,190	32.0	39.0	991	6
	36	915	0.45	0.34	484	220	11,185	49.8	8,500	37.8	7,190	32.0	39.0	991	7
	42	1065	0.55	0.50	509	231	11,185	49.8	8,500	37.8	7,190	32.0	39.0	991	8
Ditching	42	1065	0.55	0.41	472	214	12,465	55.4	8,845	39.3	7,435	33.1	35.0	889	0
	48	1220	0.60	0.46	492	223	12,465	55.4	8,845	39.3	7,435	33.1	35.0	889	0
	60	1525	0.75	0.57	564	256	12,465	55.4	8,845	39.3	7,435	33.1	35.0	889	0

# DIMENSIONS

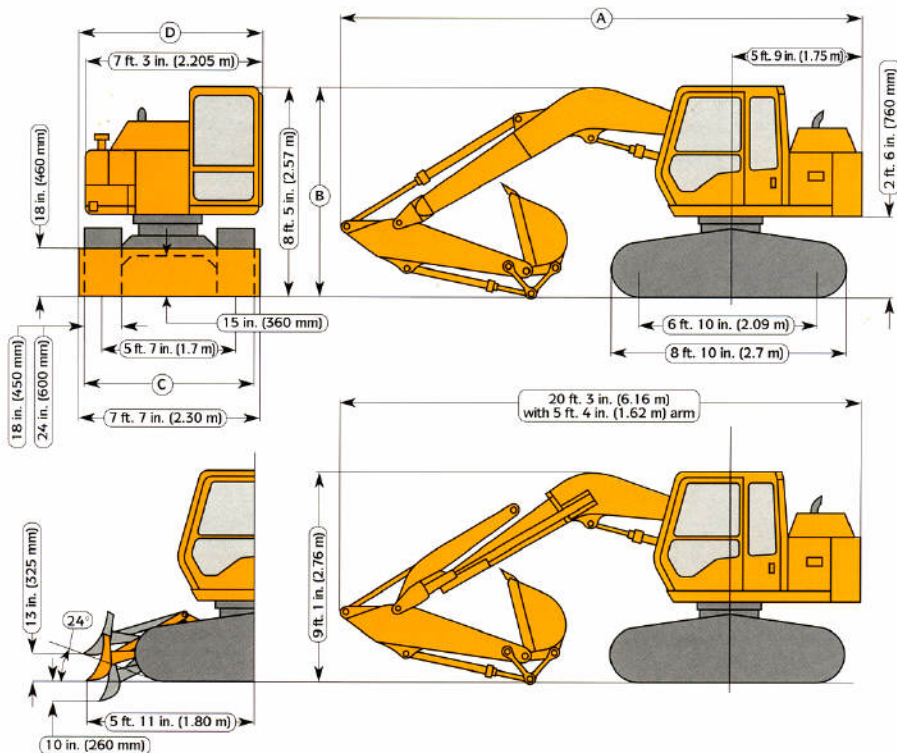

A) With 5 ft. 4 in. (1.62 m) arm.....	19 ft. 11 in. (6.08 m)
With 6 ft. 11 in. (2.12 m) arm.....	20 ft. 1 in. (6.12 m)
B) With 5 ft. 4 in. (1.62 m) arm.....	8 ft. 5 in. (2.57 m)
With 6 ft. 11 in. (2.12 m) arm.....	9 ft. 4 in. (2.85 m)
C) With 18 in. (450 mm) shoes.....	7 ft. 1 in. (2.15 m)
With 24 in. (600 mm) shoes.....	7 ft. 7 in. (2.30 m)
D) With 18 in. (450 mm) shoes,	
No blade.....	7 ft. 6 in. (2.28 m)
With blade.....	7 ft. 9 in. (2.36 m)
With 24 in. (600 mm) shoes,	
No blade.....	7 ft. 9 in. (2.36 m)
With blade.....	7 ft. 9 in. (2.36 m)

## ENGINE

It's John Deere-engineered and manufactured. Replaceable wet-type cylinder liners are spun cast and machined for uniform wall thickness to assure even heat dissipation. Piston spray cooling contributes to long component life. A dynamically-balanced crankshaft assures smooth operation.

**Engine:** John Deere 4039D

Rated power at 2,200 rpm.....	55 SAE net hp (41 kW)
	60 SAE gross hp (45 kW)
Cylinders.....	4
Displacement.....	239 cu. in. (3.9 L)
Maximum net torque at 1,400 rpm.....	153 lb.-ft. (207 Nm)
Fuel consumption, typical.....	0.8 to 1.8 gal./hr. (3 to 7 L/h)
Cooling fan.....	suction-type viscous drive
Electrical system.....	24-volt w/45-amp alternator
Batteries (two 12 volt).....	reserve capacity: 180 min.

## HYDRAULIC SYSTEM

The 190E uses an open center hydraulic system with two variable displacement pumps delivering 50 gpm (189 L/min.) for fast, smooth cycles. This highly-advanced system uses an independent, cross-sensing regulator for each of its two pumps. This two pump, two regulator system lets the operator make the best use of available horsepower by automatically adjusting hydraulic flow to the changing system requirements.

Main pumps.....	two variable-displacement axial piston
Maximum rated flow.....	2 x 25.0 gpm (2 x 94.6 L/min.)
Pilot pump.....	one gear
Maximum rated flow.....	6.2 gpm (23.5 L/min.)
Pressure setting.....	640 psi (44.15 kPa)
System operating pressure.....	
Implement circuits.....	3,770 psi (26,000 kPa)
Travel circuits.....	3,980 psi (27,444 kPa)
Swing circuits.....	4,120 psi (28,406 kPa)
Oil filtration.....	
One 10 micron full-flow return filter with bypass	
One pilot oil filter	
One suction filter	
Dozer blade pump (optional).....	one gear
Crossover relief valve:	
Blade.....	2,775 psi (19,140 kPa)
Maximum oil flow.....	6.2 gpm (23.5 L/min.)

Cylinders	Bore	Rod Diameter	Stroke
Boom (1).....	4.53 in. (115 mm)	2.56 in. (65 mm)	34.8 in. (885 mm)
Arm (1).....	3.74 in. (95 mm)	2.36 in. (60 mm)	35.4 in. (900 mm)
Bucket (1).....	3.35 in. (85 mm)	2.17 in. (55 mm)	28.7 in. (730 mm)

## SWING MECHANISM

Planetary reduction gearing is driven by an axial-piston, high-torque hydraulic motor. Ring and pinion gears are induction hardened for long life. The multiple, wet-disk swing brake is spring applied, hydraulically released. The single-row, 98-ball swing bearing is sealed top and bottom.

Swing speed.....	0-15 rpm
------------------	----------

## UNDERCARRIAGE

Heavy-duty rollers and chain are designed to stand up to the side-to-side stress of excavator work. The strong box-section track frame comes with a track guide at the front idler location. The track frames are welded to the center section to eliminate any need for periodic tightening and are designed to resist the buildup of mud and debris.

Carrier rollers (per side).....	1
Track rollers (per side).....	5
Idlers (per side).....	1
Shoes, triple semigrouser (per side).....	37
Track guides.....	front
Track adjustment.....	hydraulic
Travel speed.....	Low Medium High
	mph 0-1.6 0-2.0 0-3.1
	km/h [0-2.5] [0-3.5] [0-5.0]
Drawbar pull.....	10,360 lb. (46.0 kN)
Tractive gradability.....	84% (40 deg.)
Off-level operating limit for oil sump.....	100% (45 deg.)

### Ground Pressure Data

Shoe Width/ Grouser	Average Ground Pressure	Recommended Application
<b>Standard One-Piece Boom Without Dozer Blade:</b>		
18 in./triple (450 mm)	3.49 psi (24.1 kPa)	Rocky terrain and stumps
24 in./triple (600 mm)	2.69 psi (18.5 kPa)	General/soft terrain
<b>Standard One-Piece Boom With Dozer Blade:</b>		
18 in./triple (450 mm)	3.70 psi (25.5 kPa)	Rocky terrain and stumps
24 in./triple (600 mm)	2.84 psi (19.6 kPa)	General/soft terrain
<b>Offset Boom Without Dozer Blade:</b>		
18 in./triple (450 mm)	3.73 psi (25.7 kPa)	Rocky terrain and stumps
24 in./triple (600 mm)	2.86 psi (19.7 kPa)	General/soft terrain
<b>Offset Boom With Dozer Blade:</b>		
18 in./triple (450 mm)	3.94 psi (27.2 kPa)	Rocky terrain and stumps
24 in./triple (600 mm)	3.02 psi (20.8 kPa)	General/soft terrain

## CAPACITIES

Fuel tank.....	35.7 gal. (135 L)
Cooling system.....	11.8 qt. (11.2 L)
Engine lubrication, including filter.....	9 qt. (8.5 L)
Hydraulic tank.....	17.5 gal. (66.2 L)
Planetary propel drive (each).....	2.4 qt. (2.3 L)
Swing drive.....	1.5 qt. (1.4 L)

## OPERATING WEIGHTS

Weights	lb.	kg
Standard operating weight w/blade, offset boom, counterweight for offset boom, 24-in. (600 mm) shoes, 5 ft. 4 in. (1.62 m) arm, 0.36 cu. yd. (0.28 m <sup>3</sup> ) bucket, full fuel tank and 175-lb. (79 kg) operator.....	16,300	7394
Upperstructure for standard one-piece boom w/full fuel tank (less 1,213 lb. (550 kg) counterweight and front attachments).....	5,519	2503
Upperstructure for offset boom w/full fuel tank (less 1,323 lb. (600 kg) counterweight and front attachments).....	5,519	2503
Undercarriage:		
w/18-in. (450 mm) track shoes, w/o blade.....	4,938	2240
w/18-in. (450 mm) track shoes, w/blade.....	5,776	2620
w/24-in. (600 mm) track shoes, w/o blade.....	5,291	2400
w/24-in. (600 mm) track shoes, w/blade.....	6,129	2780
w/24-in. (600 mm) track shoes (add).....	357	162
Standard one-piece boom w/boom and arm cylinders.....	1,076	488
Offset boom w/boom and arm cylinders.....	2,185	991
Boom cylinder only.....	196	89
5 ft. 4 in. (1.62 m) arm w/bucket cylinder.....	507	230
6 ft. 11 in. (2.12 m) arm w/bucket cylinder.....	580	263
Leveling blade (add).....	838	380
Counterweight only (with standard one-piece boom).....	1,213	550
Counterweight only (with offset boom).....	1,323	600
Bucket, 0.36 yd. <sup>3</sup> (0.28 m <sup>3</sup> ).....	462	210



## JOHN DEERE BUCKETS

Choose from eight John Deere heavy-duty and ditching buckets. All are made in the U.S. to stand up to the tough digging applications of North American contractors. They feature heavy-duty reinforced top beams to assure accurate ear alignment and corner reinforcing for maximum rigidity. The T-1 steel side-cutters, a two-piece moldboard and heavy-duty wear strips assure maximum strength and increased life.



## SERVICING

Service doors on the sides and top provide access to all components, latch conveniently in the open position and are locked with the ignition key. Easy-to-read sight glasses let you check hydraulic reservoir and fuel tank levels quickly. A remote lube bank lets you grease hard-to-reach joints easily. All electric circuits route through a central fuse box. And O-ring, face seal hydraulic connections are used throughout to eliminate oil leaks and speed repairs.



## OPERATOR'S STATION

It's roomy. Visibility and ventilation are excellent. The cloth-covered seat is fully adjustable. An electronic monitoring system provides visible and audible warnings.



## OFFSET BOOM OPTION

Dig right up to foundations and abutments with this popular option. Invaluable in tight quarters, the Offset Boom Option lets you excavate outside the overall machine width. Changes from right-hand to left-hand offset hydraulically in seconds.

## ADDITIONAL STANDARD EQUIPMENT

<b>Engine:</b> Antifreeze Dual dry-type air filter Electric cold weather ether starting aid Electric fuel shutoff Fan guard Fuel filter and water separator Full-flow oil filter Heavy-duty low maintenance batteries Isolation-mounted engine Radiator trash screen Underhood muffler w/vertical exhaust	Front windshield wiper Constant speed Intermittent speed Gauges Engine coolant gauge Fuel gauge Heater, 20,000 Btu/hr (5.9 kW) with recirculation fan Horn Hourmeter (quartz) Hydraulic warm-up control Instrument lights Interior light Mode selection: Power modes—four Travel modes—three with automatic shift Monitor system with alarm features: Auto-idle indicator
--------------------------------------------------------------------------------------------------------------------------------------------------------------------------------------------------------------------------------------------------------------------------------------------------------------------------------------------	---------------------------------------------------------------------------------------------------------------------------------------------------------------------------------------------------------------------------------------------------------------------------------------------------------------------------------------------------------------------------------------------------------------------------

Engine air cleaner restriction indicator light Engine alternator charge indicator light Engine coolant temperature warning light w/audible alarm Engine oil pressure warning light w/audible alarm Hydraulic warm-up indicator Low fuel indicator Work lights-on indicator Motion alarm with cancel switch Propel pedals and levers Seat belt, 2-in. (51 mm) Tinted glass	Fuel cap Hydraulic reservoir Service doors Toolbox Work lights One mounted on boom Two mounted on frame
<b>Frame:</b> Right- and left-hand mirrors Toolbox Vandal locks Cab door	<b>Front attachments:</b> Auxiliary hydraulic valve section Bucket-to-arm clearance adjusting mechanism Centralized lubrication system Dirt seals on all bucket pins 5 ft. 4 in. (1.62 m) standard arm
	<b>Undercarriage:</b> Front track guides (idler) Planetary drive Propel motor shields Three-speed propel Upper carrier rollers

## OPTIONAL OR SPECIAL EQUIPMENT

<b>Cab:</b> AM-FM radio kit Defroster fan kit 3-in. (76 mm) seat belt 24- to 12-volt D.C. radio converters Window vandal protection covers	<b>Front attachments:</b> Attachment quick couplers Boom cylinders with plumbing to mainframe for no-boom-arm option Buckets Bucket teeth
-----------------------------------------------------------------------------------------------------------------------------------------------------------	-------------------------------------------------------------------------------------------------------------------------------------------------------

Ditching Heavy duty No-boom-arm option Offset boom option 6 ft. 11 in. (2.12 m) arm
<b>Hydraulic system:</b> Hydraulic filter restriction indicator kit

<b>Special attachments:</b> Dozer blade Laser systems
<b>Undercarriage:</b> 18-in. (450 mm) triple grouser shoes 24-in. (600 mm) triple grouser shoes

## THE JDAvantEDGE

JDAvantEdge is a wealth of support programs, parts systems, and dealer resources, all designed to give you the edge. This package of special benefits is a major reason why John Deere offers the "best value" for your equipment dollar.

**Best parts support** – Twelve regional parts depots in North America and others around the world put parts support near your job no matter where in the world it is.

A computerized FLASH™ parts locating system linking these depots to dealerships can find out-of-stock parts in a hurry and get them into your hands fast. Usually within 24 hours.

**Best service backup** – Dealer service technicians are regularly schooled, at our modern facility in Davenport, Iowa, or by professionals in the field, to diagnose quickly and repair efficiently.

If they're stumped, a phone call to DTAC (Dealer Technical Assistance Center) puts them in touch with a staff of pros at the factory who help them find a solution quickly.

**Best dealers** – Your John Deere dealer is an important contributor to the JDAvantEdge. He or she is committed to being the best equipment supplier you can work with.

This is a dollars-and-cents commitment in parts inventory, in service facilities, in field-service trucks. It's a sweat-and-blood commitment in dedicated, skilled, and highly trained and motivated personnel in each and every department at the dealership.

But what sets John Deere dealers apart from all the rest is something more, a factor somewhat difficult to measure ... a caring attitude, and a sincere desire to be the best at meeting the needs of each individual customer.

**John Deere Finance Plans** – Whether you rent, lease, or buy John Deere equipment, your dealer can explain the John Deere options available. One-stop options that let you free up operating capital, keep other lines of credit open. More solid benefits of the JDAvantEdge.

**Best protection** – In addition to the new equipment warranty that meets or exceeds the competition, SECURE® extended coverage, an optional service product for John Deere equipment, is available for repair coverage after the warranty concludes. Full machine or power train coverage is available for a variety of time periods to meet your needs. Consult your dealer for availability and details.



SINCE 1924

**Ted B. Miller Co. Inc.**  
220810 Hwy. 92 East  
P.O. Box 400  
Gering, Nabr. 60341  
Phone #603-435-2177



Net engine power is with standard equipment including air cleaner, exhaust system, alternator and cooling fan. Gross power is without cooling fan. Power ratings are at standard conditions per SAE J1549 and DIN 6270B. No derating is required up to 6000 feet (1800 m) altitude.

Specifications and prices subject to change without notice. Wherever applicable, specifications are in accordance with PCSA and SAE Standards. Except where otherwise noted, these specifications are based on a unit equipped with 0.56 yd.<sup>3</sup> (0.28 m<sup>3</sup>) 30 in. (760 mm) bucket, 24-in. (600 mm) triple grouser shoes, counterweight, 5 ft. 4 in. (1.62 m) arm, full fuel tank, 175-lb. (79 kg) operator and standard equipment.

