

**CAT**<sup>®</sup>**426**  
SERIES II**BACKHOE LOADER**

- **Load-Sensing Hydraulics** — maximum hydraulic force to cutting edges at all engine speeds.
- **Reliable/Durable** — built to withstand severe working conditions.
- **Operating Ease** — convenient, easy-to-reach, low-effort controls.
- **Service and Maintenance Ease** — conveniently located service points, all accessible from the ground.
- **Total Customer Support System** — unmatched in the industry!

---

Gross Power . . . . .	56 kW/75 HP
Flywheel Power . . . . .	52 kW/70 HP
Operating Weight . . . . .	6633 kg/14,626 lb
Backhoe digging depth up to . . . . .	6004 mm/19'8"

---

Featured machines may include additional equipment applicable only for special applications. See your authorized Caterpillar dealer for available options.



## ■ Durable boom and stick.

- Boom is a welded fabrication with large castings at high stress areas.
- Foot casting is attached to swing frame by a large-diameter, floating pivot pin for equalized wear, increased pin life.
- Stick is tapered, rectangular unit with a large wrapper sheet for maximum durability.

## ■ Versatile, two-position bucket linkage.

- Maximum digging force in either pin position for heavy digging requirements.
- 190° of bucket rotation for superior load retention and deep vertical wall digging.

## ■ Heavy duty main frame.

- Fully welded, one-piece frame absorbs stress and minimizes shock loads to the power train.
- Integral backhoe reduces maintenance and service . . . for a true backhoe loader.

## ■ Excellent hose routing.

- Reduces leaks.
- Reduces hose damage.
- Prolongs life.
- Allows easy accessibility.

## ■ Overcenter backhoe design.

- Transfers weight to the front axle for excellent machine balance and superior roading capabilities.
- Automatic transport lock.
- Excellent ground clearance to the bucket.

## ■ Operator's compartment.

- Designed for operator comfort and efficiency.
- Quiet, roomy, uncluttered, with entry from either side of machine.

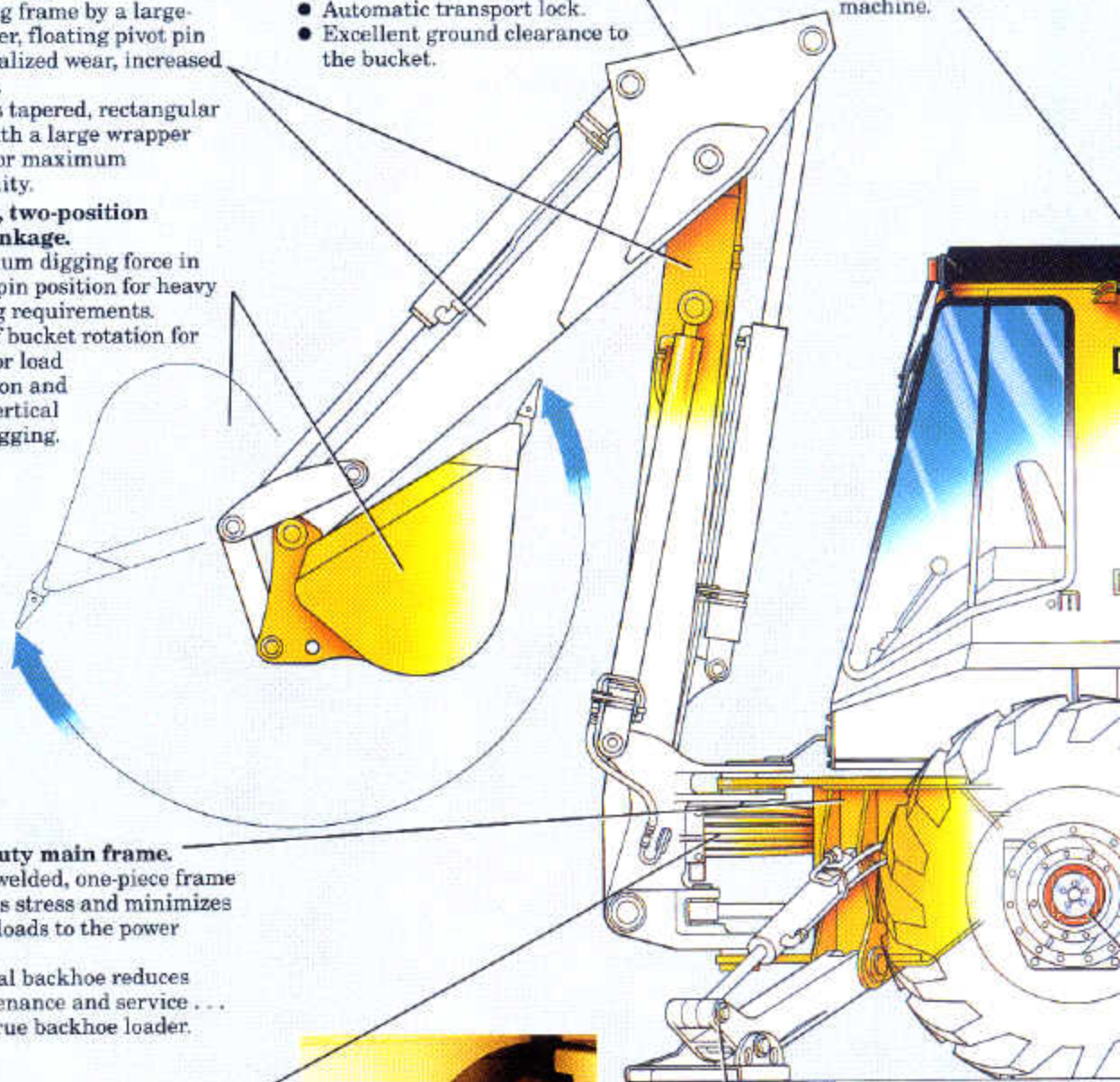

## ■ Stabilizers have optional shoe styles available to match job requirements.

- Grouser pad — durable ductile iron footpad for soil applications.
- Street pad — suitable for blacktop, and areas damaged by grouser stabilizer pad.
- Flipover pad — gives user ability to convert from soil to pavement surfaces, vice-versa, just by flipping the pad.



## Standard Equipment

**NOTE:** Standard and optional equipment may vary. Consult your Caterpillar dealer for specifics.

Air cleaner, dry-type.  
 Alternator, 52-amp, 12-volt.  
 Backhoe, 4688 mm/15'5" center-pivot two-lever control.  
 Battery, maintenance free, 700 CCA.  
 Brace, lift cylinder.  
 Brake, parking.  
 Brakes, oil-disc.  
 Cooler, hydraulic oil.  
 Differential lock.  
 Engine enclosure.  
 Fan, suction.  
 Fast reversing shuttle, all gears.  
 Fenders, rear.  
 Flashing hazard/signal lights.  
 Front axle trunnion, remote lube.  
 Front grill, impact absorbing.  
 Front and rear Halogen working lights (4).

Gauges:  
 Coolant temperature.  
 Fuel level.  
 Tachometer.  
 Torque converter oil temperature.  
 Voltmeter.  
 Indicators:  
 Air cleaner service.  
 Brake on.  
 Clock hour meter.  
 Engine coolant (also audible alarm).  
 Hydraulic oil level sight gauge.  
 Oil pressure (also audible alarm).  
 Instrument panel lights.  
 Loader, self-leveling with Return to Dig and transmission disconnect switch on single-lever control.  
 Mirror, rear view.

Power steering.  
 Precleaner.  
 ROPS canopy, with dual access.  
 Seat, vinyl suspension, fully adjustable with armrests.  
 Seat belt (76 mm/3").  
 Starting aid, ether.  
 Starting system, electric.  
 Storage compartment, internal.  
 Stop and tail lights (2).  
 Tires:  
 Front 11L-16 12 PR  
 Rear 16.9-24, 8 PR  
 Tool box, external.  
 Torque converter.  
 Throttles, hand and foot.  
 Transmission, four-speed synchromesh.  
 Vandalism protection.  
 Warning horn, front, electric.



## Optional Equipment

(with approximate change in operating weight)

	Kg	Lb
Air conditioner	45	99
Alarm, back up (required in North America)	1	2
Backhoe bucket adapter kit	31	68
Backhoe control lever options (each)	9	20
Battery group, heavy duty	28	61
Buckets: backhoe, loader	See page 12	
Cab, ROPS (includes heater, defroster and pressurizer)	231	509
Counterweight	227	500
Cutting edge, bolt-on (loader bucket)	39	86
Fan, operator's compartment	2	4
Floor mat, ROPS canopy	5	10
Fold over forks for MP bucket	264	582
Four-wheel drive	120	265
Guards:		
Hose guard, boom base	1	2
Boom cylinder	39	86
Stabilizer cylinder	59	130
4wd driveshaft	29	64
Hydraulic lines for continuous flow attachments	93	206
Increased performance backhoe	228	503

	Kg	Lb
Hydraulic arrangements:		
3rd valve, for loader	12	26
7th valve, backhoe, for stick-mounted attachments	5	10
7th and 8th valves, backhoe, for additional circuits on std. stick	9	20
8th valve, backhoe, for unit equipped with extendable stick and second additional circuit	6	14
Additional hydraulic line to boom	4	9
Mirrors, outside mounted	17	37
Muffler, spark-arresting	4	9
Narrow gauge rear tires	—	—
Radio installation kit	3	7
Rotating beacon	5	11
Sound suppression, exterior	11	24
Speedometer	2	5
Stabilizer street pads	37	82
Static seat, vinyl	-21	-46
Stick, extendable	252	556
Suspension seat, fabric	15	33
Tires	See page 9	
Tooth tip options	See page 12	
Turbocharger, altitude compensating	20	45

**NOTE:** All specification dimensions are rounded.

**Loader Dimensions (SAE J732c)**  
**Loader Bucket Capacities (SAE J742)**

Type	General Purpose	Multi-Purpose
Width . . . . . (mm/in)	2262/89"	2262/89"
Heaped capacity . . . . . (m <sup>3</sup> /yd <sup>3</sup> )	0.96/1.25	0.76/1.00
Lift capacity at full height . . . . . (kg/lb)	2450/5,401	2385/5,258
Breakout force . . . . . (kg/kN/lb)	3480/34.1/7672	3923/38.5/8649
Hinge pin height . . . . . (mm/ft/in)	3297/10'10"	3297/10'10"
Dump angle full height . . . . .	46°	46°
Dump height at 45° . . . . . (mm/ft/in)	2562/8'5"	2668/8'9"
Reach at full height/45° . . . . . (mm/in)	776/31"	628/25"
Maximum operating height . . . . . (mm/ft/in)	4177/13'8"	4145/13'7"
Maximum rollback at ground . . . . .	40°	41°
Digging depth . . . . . (mm/in)	102/4"	132/5"
Grading angle . . . . .	108°	99°
Width of dozer cutting edge . . . . . (mm/in)	—	2262/89"
Clam opening — maximum . . . . . (mm/in)	—	958/38"
Weight . . . . . (kg/lb)	428/944	559/1,232

**Backhoe Bucket Capacities (SAE J296)**

Width		Capacities				Weight		No. of Teeth
		Heaped		Struck				
mm	in	L	cu ft	L	cu ft	kg	lb	
305	12	70	2.5	60	2.0	88	193	3
457	18	140	5.0	110	4.0	118	259	4
610	24	200	7.0	160	5.5	133	294	4
762	30	280	10.0	200	7.0	149	329	5
914	36	340	12.0	260	9.0	165	364	6

**Teeth Options**

- Utility
- Penetration
- Abrasion
- Short
- Long

**Note:** — Heavy-duty bucket available in all widths.  
 — Extreme service buckets available in 457 mm/18" and 610 mm/24" widths.





## Machine Dimensions (SAE J49 and J732c)

	mm	ft/in
Overall transport length	6917	22'8"
Overall length (loader on ground)	6957	22'10"
Overall transport height	3742	12'2"
Overall width, with bucket	2262	7'5"
Height to top of canopy	2714	8'11"
Height to top of cab	2714	8'11"
Height to top of exhaust stack	2747	9'
Height to top of steering wheel	1948	6'4"
Height to loader hinge pin (transport)	376	15"
Ground clearance (machine main frame)	291	11"
Rear axle centerline to front grill	2610	8'7"
Front wheel tread	1780	5'10"
Rear wheel tread	1714	5'7"
Wheel base (2WD)	2100	6'11"
(4WD)	2067	6'9"

**NOTE:** Specifications are based on a machine equipped with 11L-16.12 PR front tires, 16.9-24.8 PR rear tires, ROPS canopy, 4688 mm/15'5" backhoe with 610 mm/24" standard duty bucket, loader with 2262 mm/89", 0.96 m<sup>3</sup>/1.25 yd<sup>3</sup> General Purpose bucket and standard equipment unless otherwise specified.

## 426 BACKHOE LIFT CAPACITY: Standard Stick

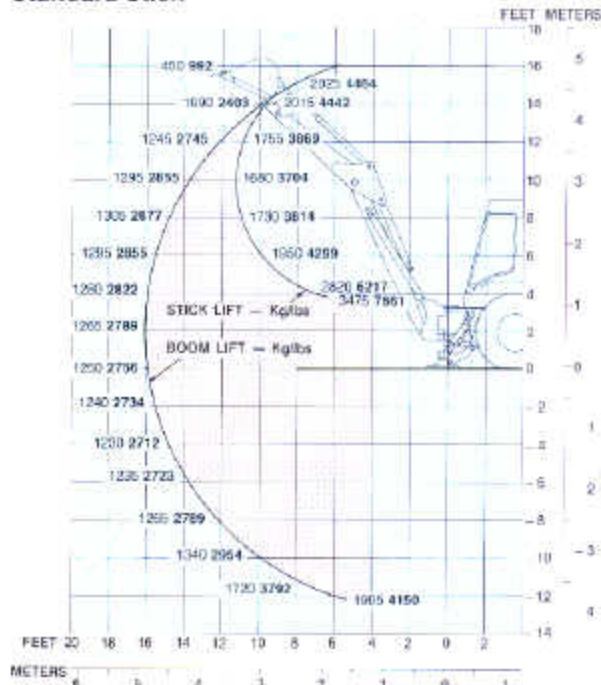

## 426 BACKHOE LIFT CAPACITY Extendable Stick — Retracted

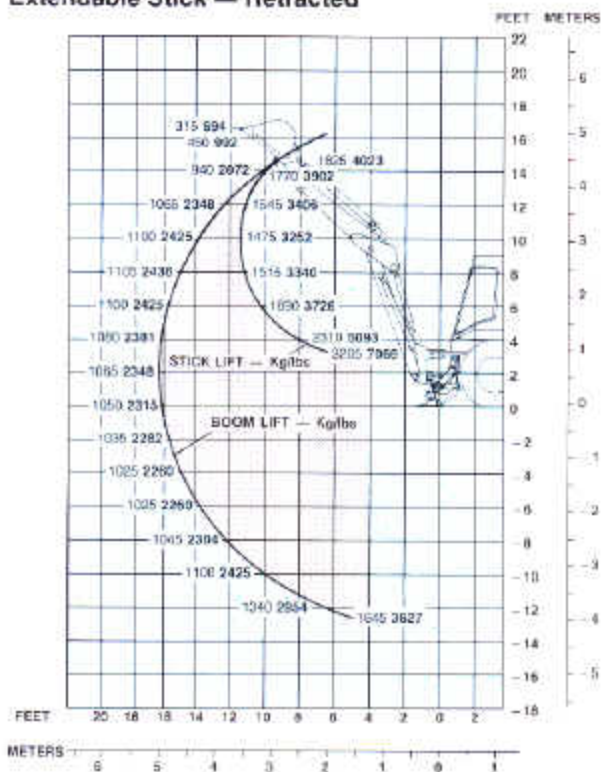

**NOTE:** Lift capacities as per SAE J31 with loader bucket on ground and boom at 65° from horizontal are 87% of hydraulic maximum.

## 426 BACKHOE LIFT CAPACITY Extendable Stick — Extended

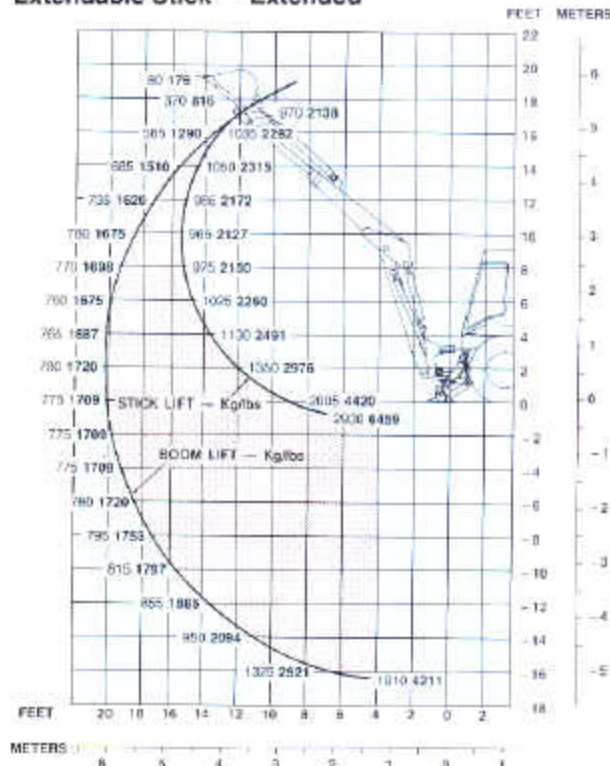

# SPECIFICATIONS

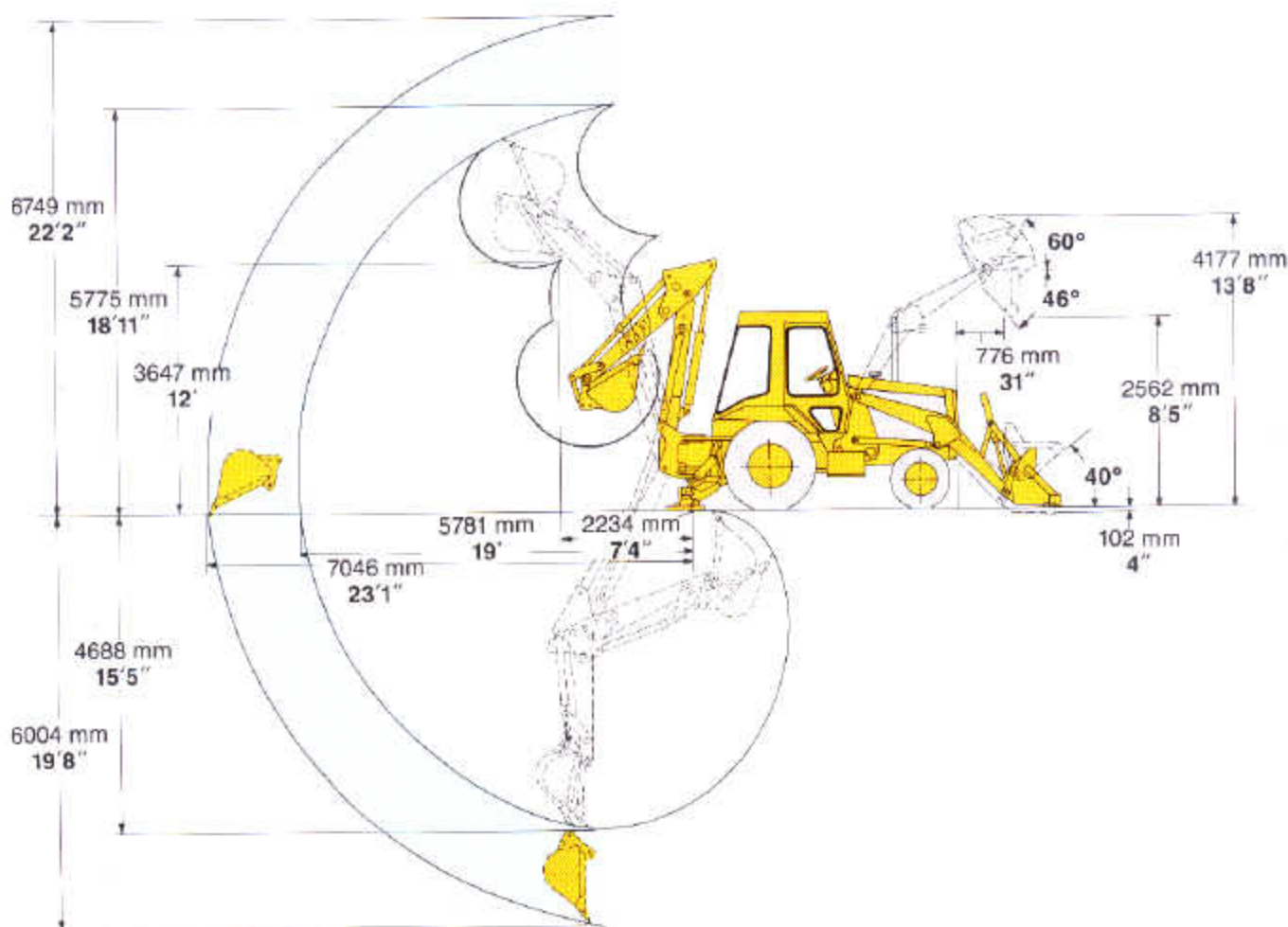

## Backhoe Dimensions

	Extendable stick		
	Standard stick	Retracted	Extended
Digging depth — SAE (max)	4688 mm 15'5"	4792 mm 15'9"	6004 mm 19'8"
610 mm/2' flat bottom	4663 mm 15'4"	4768 mm 15'8"	5977 mm 19'7"
Overall reach from rear axle centerline at ground line	6871 mm 22'7"	6979 mm 22'11"	8136 mm 26'8"
Overall reach from swing pivot at ground line	5781 mm 19'0"	5889 mm 19'4"	7046 mm 23'1"
Maximum operating height	5775 mm 18'11"	5838 mm 19'2"	6749 mm 22'2"
Loading height	3647 mm 12'0"	3650 mm 12'0"	4335 mm 14'3"
Loading reach	2234 mm 7'4"	2415 mm 7'11"	3423 mm 11'3"
Swing arc	180°	180°	180°
Bucket rotation			
#1 position	169°	162°	162°
#2 position	169°	162°	162°
Stabilizer spread — operating position	3254 mm 10'8"	3254 mm 10'8"	3254 mm 10'8"
Stabilizer spread — transport position	2130 mm 7'0"	2130 mm 7'0"	2130 mm 7'0"
Digging force, bucket cylinder, SAE	46.4 kN 10,440 lb	45.6 kN 10,260 lb	45.6 kN 10,260 lb
Digging force, stick cylinder, SAE	35.2 kN 7,920 lb	34.3 kN 7,718 lb	23.9 kN 5,378 lb
Leveling angle (maximum slope on which backhoe will make vertical cut)	14°	14°	14°



### Hydraulic system

Variable-flow, load-sensing, pressure-compensating design provides efficient use of power and low effort controls.

Type ..... Closed-center  
 Pump type ..... Variable flow, axial-piston  
 Pump capacity ..... 138 l/min/**36.4 gpm** at 2400 RPM  
 System pressure ..... 18 600 kPa/186 bar/**2700 psi**



### Steering

Steering unit provides emergency steering capability in case of power failure.

Type ..... Front wheel  
 Power steering ..... Hydrostatic  
 Cylinder (1) ..... double-acting, bore 76 mm/3" stroke 220 mm/8.7", rod diameter 48 mm/1.9"  
 Turning radius, (wheels not braked),  
 two-wheel drive ..... 3905 mm/12'10"  
 four-wheel drive engaged ..... 4616 mm/15'2"



### Tires

Type	Size	Ply Rating
<b>Front</b>		
Standard 2wd	11L-16	12
Standard 4wd	10.5-20	10
Optional 2wd (flotation)	10.5-20	10
Optional 4wd	12.5/80-18	10
<b>Rear</b>		
Standard 2wd	16.9-24	8
Optional 2wd	16.9-24	10
Optional 2wd	19.5L-24	8
Standard 4wd	19.5L-24	8
Optional 2 or 4wd	19.5L-24	10



### ROPS

ROPS canopy is standard in U.S.A.

ROPS (Rollover Protective Structure) offered by Caterpillar for this machine meets ROPS criteria SAE J394, SAE J1040 APR88 and ISO 3471-1986. It also meets FOPS (Falling Object Protective Structure) criteria SAE J231 and ISO 3449-1984.



### Cab

Cab offered by Caterpillar, when properly installed and maintained, and tested with doors and windows closed according to ANSI/SAE J1166 JUL87, meets OSHA and MSHA requirements for operator sound exposure limits in effect at the time of manufacture.



### Service Refill Capacities

	Liters	U.S. Gallons
Cooling System	21	5.5
Fuel Tank	106	28
Engine Oil with Filter	7	7.4 qts.
Transmission	10	10.6 qts.
Rear Axle	18.5	19.5 qts.
Hydraulic Reservoir	38	10
Hydraulic System	82	21.7
Four-Wheel Drive Front Axle	7.5	2.0



### Weights

Standard backhoe loader with additional: 0.96 m<sup>3</sup>/1.25 yd<sup>3</sup> General Purpose loader bucket, 610 mm/24" backhoe bucket, 79 kg/175 lb operator, full fuel tank. SAE Operating weight ..... 6633 kg/14,626 lb

	Kg	Lb
Cab	+231	+509
Four-wheel drive	+120	+265
Extendable stick* (excludes CTWT)	+252	+556
Multi-purpose bucket	+131	+288

\*Includes 16.9-24 10 PR tires.

## Engine

Gross power at 2400 RPM . . . . . 56 kW/75 HP  
 Flywheel power at 2400 RPM . . . . . 52 kW/70 HP  
 (Kilowatts (kW) is the International System of Units equivalent of horsepower.)

*Net power at the flywheel of the vehicle engine is based on SAE J1349 standard conditions of 25° C/77° F and 100 kPa/29.61" Hg. Power is based on using 35° API (15.6° C/60° F) gravity fuel having an LHV of 42 780 kJ/kg (18,390 Btu/lb) when used at 29.4° C/85° F and with a density of 838.9 g/L (7.001 lb/U.S. gal). Power rating is adjusted for vehicle equipped with fan, air cleaner, alternator, water pump, fuel pump, muffler and lubricating oil pump. No derating is required up to 1500 m/5000 ft. altitude.*

These additional ratings also apply at 2400 RPM

	Naturally Aspirated		Turbocharged	
	kW	HP	kW	HP
ISO 1585 . . . . .	52.2	70.0	52.9	70.9
ISO 3046-1 . . . . .	51.8	69.5	52.1	69.8
EEC 80/1269 . . . . .	52.2	70.0	52.9	70.9
	kW	PS	kW	PS
DIN 6271-1 . . . . .	51.8	70.4	52.1	70.8
DIN 70020 . . . . .	53.3	72.4	52.9	71.9

Percent torque rise (Net)	
Naturally Aspirated . . . . .	16.7
Turbocharged . . . . .	29.3

Perkins four-stroke-cycle 4.236 diesel engine with four cylinders, 98.4 mm/3.87" bore, 127 mm/5.0" stroke and 3.86 liter/236 cu. in. displacement.

Dry-type, slip-fit liners — pre-finished for ease of run-in and service replacement.

Cast-iron sump — resists impact damage. Steel-backed aluminum bearings. Heat-treated crankshaft. Pressure lubrication with full flow filtered oil. Dry-type air cleaner with primary and secondary elements and pre-cleaner. Separate fuel filter and water separator. Direct-electric, 12-volt starting system with 52-amp alternator and ether starting aid standard. Choice of one or two maintenance-free batteries with 700 cold cranking amps.

## Brakes

**Service** — Two fully-enclosed, self-energizing oil-disc brakes on final drive input shaft. Foot-operated, brake pedals can be interlocked for roading or used independently in working applications.

**Parking/Secondary** — Two fully enclosed, self-energizing, oil disc brakes on final drive input shaft. Operator applies manually.

## Transmission

Four speeds forward and reverse — full synchromesh in all gears. Constant-mesh gears on all ratios permit on-the-go shifting of all gears — up or down. Neutral start provision prevents starting machine while transmission is in gear.

### Transmission Disconnect

Hand-operated power disconnect (no clutch) for on-the-go shifting and full engine RPM for faster cycle times.

### Torque Converter

Single stage, 2.21:1 stall ratio.

### Forward/Reverse Power Shuttle

Conveniently placed, hand-operated lever provides instant on-the-go direction changes from forward to reverse with power hydraulic clutches.

### Travel Speeds

Travel speeds of two-wheel drive backhoe loader at full throttle equipped with 16.9-24, rear tires.

	1st		2nd		3rd		4th	
	Km/H	MPH	Km/H	MPH	Km/H	MPH	Km/H	MPH
Forward	5.5	3.4	10.4	6.5	20.1	12.5	31.5	19.6
Reverse	5.6	3.5	10.5	6.5	20.2	12.6	31.6	19.6

## Axles

Axle rating, two-wheel drive

Front axle	
SAE J43 . . . . .	7517 kg/16,575 lb
Dynamic . . . . .	30 068 kg/66,300 lb
Rear axle	
SAE J43 . . . . .	5749 kg/12,677 lb
Dynamic . . . . .	22 996 kg/50,706 lb

### Rear Axle

Heavy duty axle with inboard planetary reduction and differential lock.

**Front Axle**, standard two-wheel drive or optional four-wheel drive.

Oscillation 11° each direction from centerline. Switch on instrument panel engages four-wheel drive, on-the-move, in any gear, forward and reverse.

Drive from differential to front wheels via planetary reduction in each wheel. On-the-go shifting up or down in all gears is retained in four-wheel drive.

## Total Customer Support

Unmatched in the industry!

- **Parts availability** — Most Cat parts are immediately available off the shelf. Dealer parts availability is backed up by Cat's computer-controlled, emergency search system.
- **Service capability** — Whether in the dealer's fully equipped shop or in the field, you'll get trained service people using the latest technology and tools.
- **Machine management service** — Cat dealers help manage equipment investments with:
  - Effective preventive maintenance programs.
  - Diagnostic programs like Scheduled Oil Sampling and Technical Analysis.
  - Information to make the most cost-effective repair options decisions.
  - Customer meetings, training for operators and mechanics.



- **Exchange components for quick repairs** — Low-cost components assure maximum, cost-effective uptime.

- **Literature support** — Easy-to-use operation and maintenance manuals help you get the full value out of your equipment investment.





## Cat® Hydraulics

Automatically match hydraulic flow and pressure requirements to work demands, a necessity for top backhoe loader productivity and efficiency.

- **Variable-displacement, load-sensing system** — maximum hydraulic force is transferred efficiently to the cutting edges for superior performance at any engine speed.
- **Variable-flow, axial-piston pump** — matches speed and power requirements for efficient fuel usage.
- **Control valves** — pressure compensated for low lever efforts. Stacked design provides servicing ease.

- **Caterpillar's XT-3 hose** — proven reliable for long-life performance. Excellent hose routing reduces hose damage.
- **O-ring face seals** — minimize leaks for a virtually dry machine.
- **Hydraulic cylinders** — designed and built for durability. Long life seals for leak-free operation.



## Structure Built to withstand the toughest working conditions.

- **Fully welded, one-piece frame.**
  - Designed to absorb stress and minimize shock loads to the power train.
  - Integral backhoe — reduces maintenance and service, backhoe frame is a welded part of the tractor main frame.
  - Box-section side frames add structural strength and long life.
- **Large-diameter axle trunnion and bearings** — greater wear surface, longer life.
- **Boom** — welded fabrication with large castings at high stress areas.
- **Stick** — reinforced with a large wrapper sheet to reduce stress.
- **Pins and bushings** — large diameter, heat treated for long life.

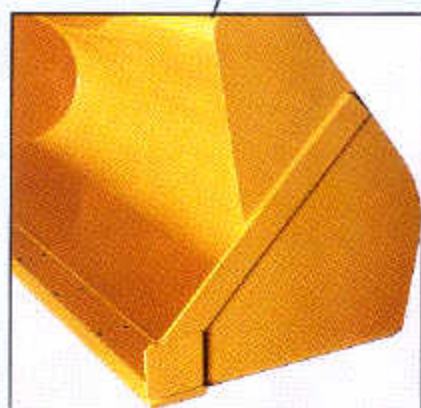
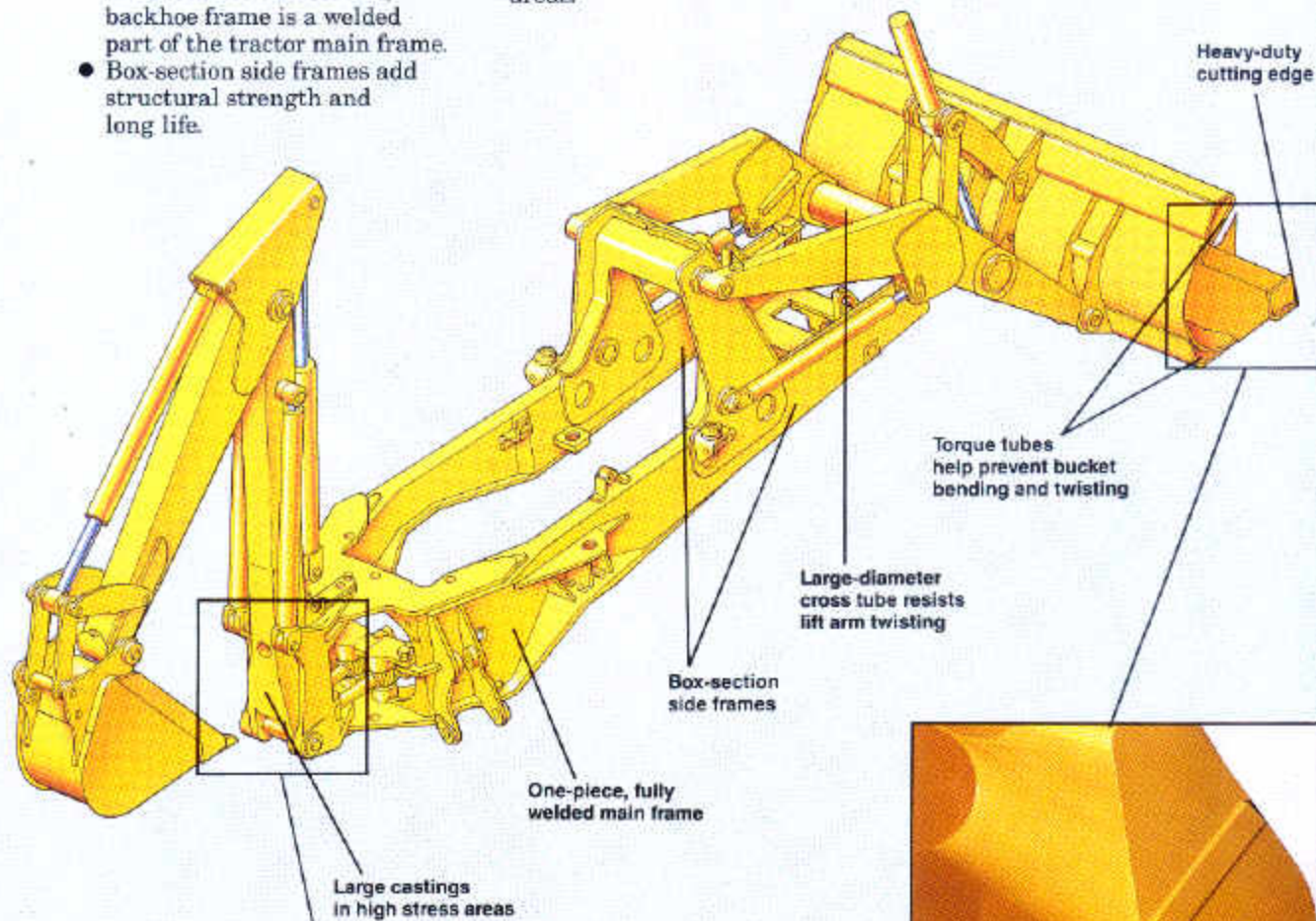

## Operator's Station Designed for operator ease and comfort.

- **Dual access** — either side entry to operator's compartment.
- **Convenient controls** — low-effort, easy-to-reach, for day-long productivity.
- **Resiliently mounted cab** — isolates the operator, reduces noise and vibration.
- **Side-mounted gauge panel** — visible while operating either loader or backhoe.
- **Audible/visual warning system** — continuous operator awareness of machine functions.
- **Rear-mounted hand throttle** — easy actuation from backhoe position.
- **Fully adjustable suspension seat** — for added operator comfort.
- **Transmission disconnect switches** — on loader control and gear shift levers to reduce cycle times and simplify speed changes when roading . . . fast, convenient actuation.
- **Excellent visibility** — outstanding forward and rear view from the operator's seat to the loader and backhoe.

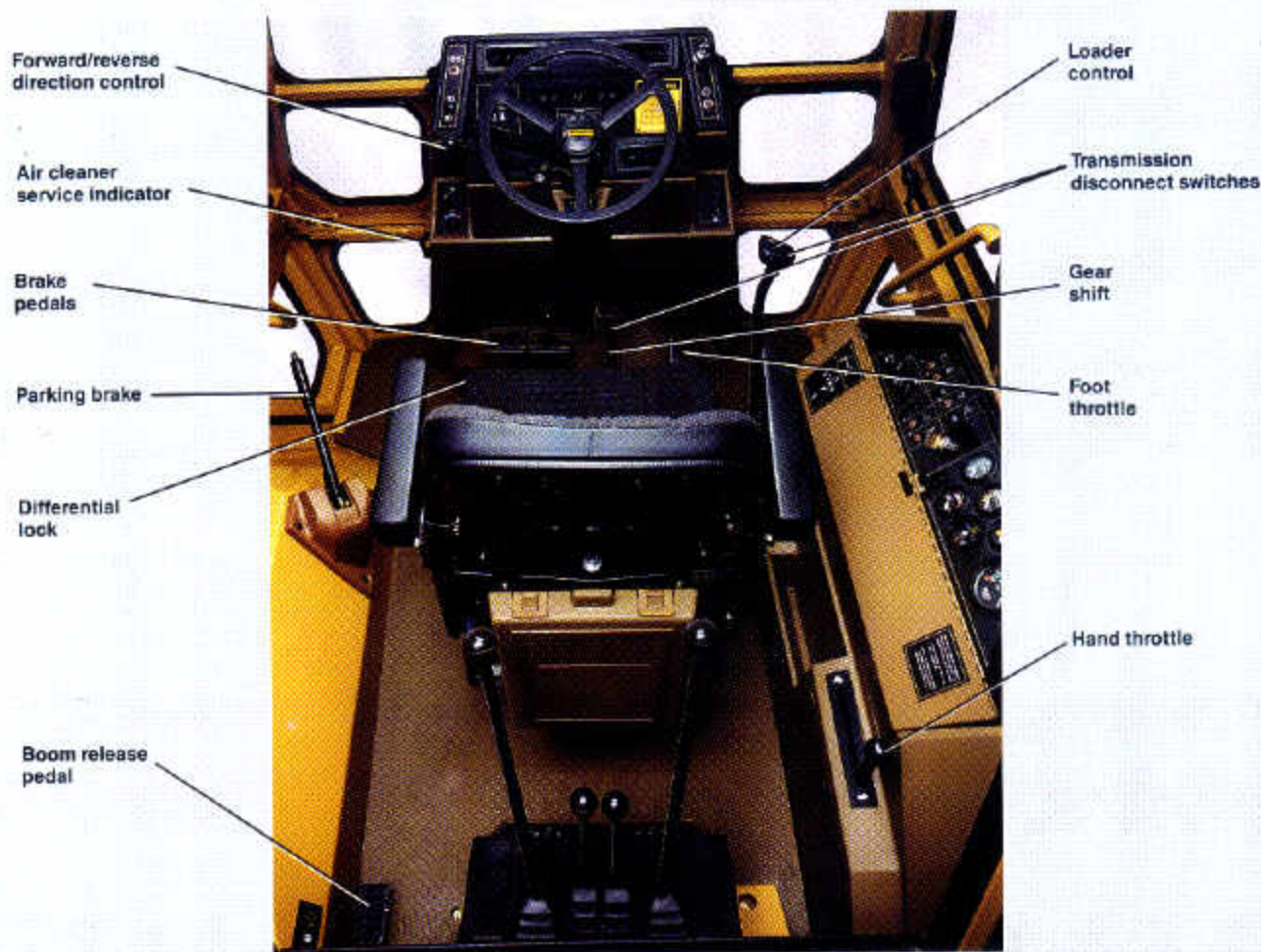

■ **Fully synchronized transmission.**

- On-the-go shifting in all gears, two- or four-wheel drive.
- All-wheel drive engaged on-the-go by the flip of a switch.
- Modular for easy servicing.

■ **Return to Dig with automatic bucket leveling.**

- Improved operator efficiency.

■ **Heavy duty diesel engine.**

- Provides long service life.
- Prefinished dry liners for simplified rebuild.
- Cast oil sump resists impact damage.

■ **Hydraulic tank.**

- Strategically positioned for optimal balance and weight distribution when roading.
- Sealed to prevent contamination.
- Removable for easy repair or cleanout.

■ **Variable-flow, axial-piston hydraulic pump.**

- Automatically matches power to work demands.
- Reduces fuel consumption.
- Provides full hydraulic force at any engine speed.

■ **Divergent loader arms.**

- Excellent visibility – allows a clear view to the bucket corners.

■ **Single tilt cylinder.**

- Provides good visibility with fewer wear and service points.

■ **Rugged front axle.**

- Heavy-duty box section construction on two wheel drive.
- Two large, 140 mm/5½" trunnion bearings support axle to ensure durability.
- Short steering rods well protected from the work environment for long life performance.
- Large diameter steering cylinder resists bending.
- Remote hube points for front axle trunnion simplify maintenance procedures.

■ **Rear axle.**

- Forged steel, induction-hardened axle shafts for drive-line longevity.
- Differential lock reduces wheel spin.
- Oil-immersed, multi-plate disc brakes for long service life.
- Modular for easy servicing.

■ **General purpose loader bucket.**

- Top of the bucket is parallel to the cutting edge, providing a built-in level indicator.
- Vertical heel plate for excellent back dragging capabilities.
- Reinforced torque tubes help prevent bucket distortion when lifting objects or backfilling.
- Pre-drilled base edge accepts bolt-on teeth or replaceable cutting edges.

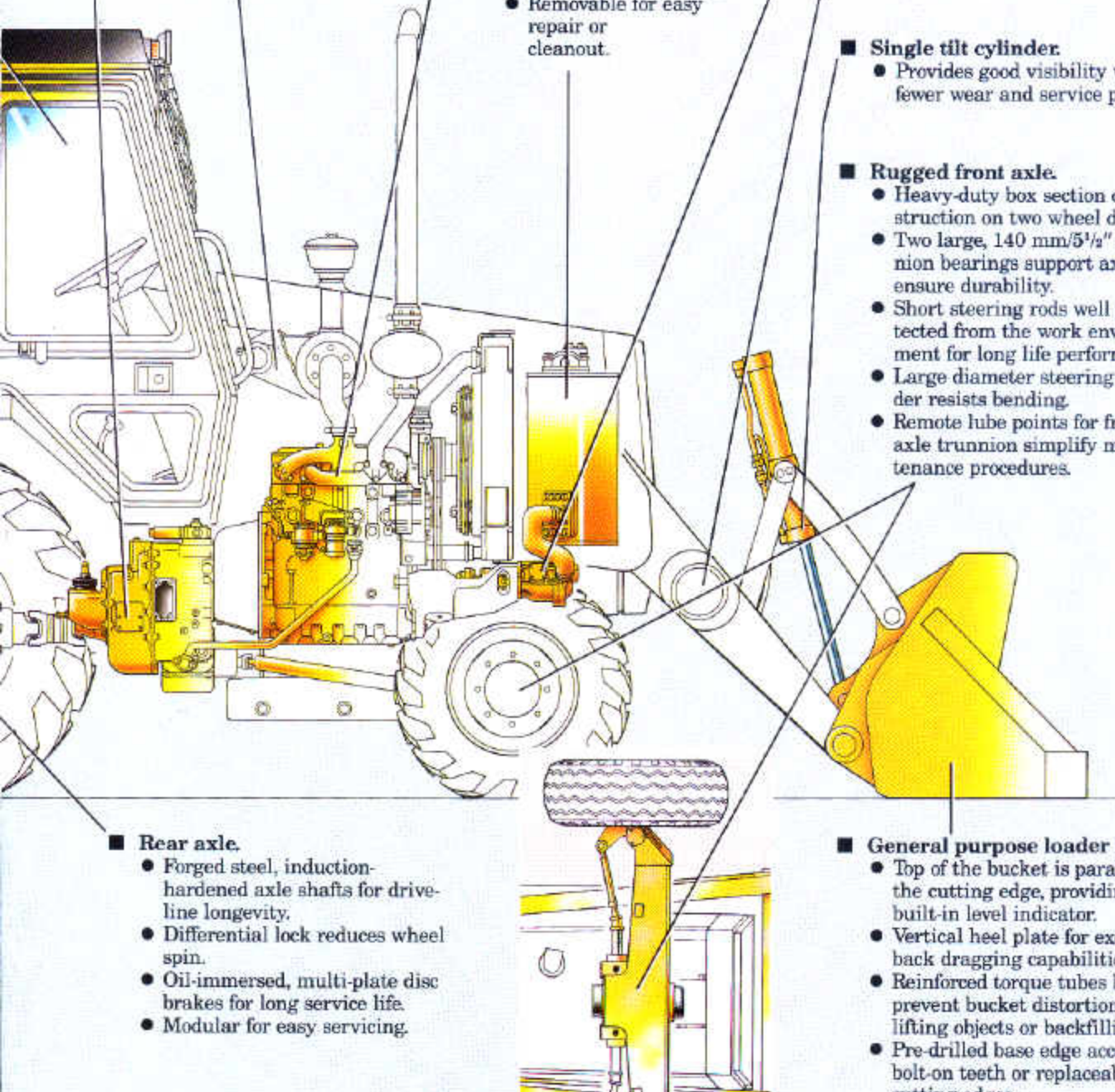

## The Competitive Edge

### Performance

- **Load-sensing hydraulic system** — full hydraulic force to cutting edges at all engine speeds.
- **Fully synchronized transmission** — on-the-go shifting in all four gears, two- or four-wheel drive.
- **3480 kg/34.1 kN/7,672 lb loader bucket breakout force** — excellent production capabilities.
- **Automatic bucket leveling/Return-to-Dig** — improved operator efficiency, lower cycle times, increased productivity.
- **Versatile, two-position bucket linkage** — maximum digging force in either pin position for best match to job.
- **Overcenter backhoe design** — excellent stability, fast travel to and from job.

### Reliable/Durable

- **Main frame** — fully welded, one-piece frame designed to absorb stress and minimize shock loads to the power train.
- **Integral backhoe** — reduces maintenance and service ... for a true backhoe loader.
- **Load-sensing hydraulic system** — proven reliable, on-demand hydraulics.
- **Caterpillar XT-3 hose with O-ring face seal connectors** — designed to provide a virtually dry machine.
- **Sure Seal connectors** — on electrical system, moisture proof and positive locking for reliable long life.

### Maintenance/Repair

- **Modular components** — remove as a single unit for simpler, quicker repairs, less downtime.
- **Superior hose routing** — reduces hose damage, easily accessible for service.
- **Service points** — conveniently located, all accessible from the ground.
- **Built-in lift cylinder brace** — suspends loader arms for engine servicing.

### Operating Ease

- **Conveniently placed, precise, low-effort controls** — increase operator efficiency.
- **Adjustable seat** — for added operator comfort.

- **Hydrostatic steering** — effortless control, even at low idle.
- **Excellent visibility** — outstanding forward and rear view from the operator's seat to the loader and backhoe.

### Total Customer Support System

- **Parts availability** — most Cat parts on dealer's shelf when you need them — computer-controlled, emergency search system backup.
- **Service capability** — dealer's shop or fast field service — trained service people — latest tooling and technology.
- **Machine management services** — effective preventive maintenance programs, diagnostic programs (Scheduled Oil Sampling, Technical Analysis), cost-effective repair options, customer meetings, operator and mechanic training.
- **Exchange components for quick repairs** — choose remanufactured products or rebuilt components for maximum availability and lower costs.
- **Literature support** — easy-to-use operation, maintenance guides help you get the maximum value out of your equipment investment.
- **Flexible financing** — your dealer can arrange attractive financing on the entire line of Cat equipment. Terms structured to meet your cash flow requirements. See how affordable and easy it is to own Cat equipment.

### Custom Machine Products

- In addition to the standard range of optional equipment, special attachments and machine configurations to suit particular customer applications can be made. Contact your Caterpillar® dealer for details on matching the Caterpillar product to your special applications.

The Caterpillar logo consists of the word "CATERPILLAR" in a bold, sans-serif font. A yellow triangle is positioned below the letter "A", pointing upwards.